

Job Name: 25-1267B Grocery Owensboro KY  
 Job Location: Owensboro, KY  
 Contractor: Winwater Hartford KY Co.

Plant: Beaver Dam

9/18/2025 12:09:29 PM

Tech: J. Coppage

PC: A. Chambers



**Structure ID: CB-G4**

**P1 MH048BAVF**

**MH BASE Custom Ht**

- P2) 48" - MH MONOTOP Special, Custom Ht - 25"
- P1) 48" - MH BASE Custom Ht - 28"
- 1) 48" - SGL 1"x14.5' Butyl (2x)
- 1) Hole - 24
- 4) Horiz Slot - 30"x6"
- 4) MH Step ML-10-TDS-NCR - 10"

2108 lb  
 3136 lb  
 0 lb  
 0 lb  
 0 lb  
 0 lb

Structure Total: 5244 lb

- Structure Notes:**
1. JR HOE MCS-288 STORM PROVIDED BY ICAST.
  2. PER ASTM C478 SPECIFICATIONS.
  3. CONCRETE = 4,000 PSI AT 28 DAYS.
  4. REINFORCING PER ASTM A615 (GRADE 60).  
 - TOP SLAB (As .62) #5 BARS AT 6" C.C.E.W..  
 - RISER/WALLS (As .12)  
 - FLOOR (As .31) #5 BARS AT 12" C.C.E.W.

Rim: 402' Rim to Invert: 4.28' Slack: -0.04" Sump: 1.6" Step Position: 180°

Position	Elev	Angle	Ext. (cw)	Pipe	Pipe OD	Connector	Hole	Horz Size	Up ( )	Offset
Invert 1	397.72'	90°	45.553"	18" HDPE	21.2"	Hole 24	24"	25.133"	0"	0"
Invert 2										
Invert 3										
Invert 4										
Invert 5										
Invert 6										
Invert 7										
Invert 8										

RIGHT-SIDE UP VIEW (int. dimensions)

UPSIDE-DOWN VIEW (int. dimensions)

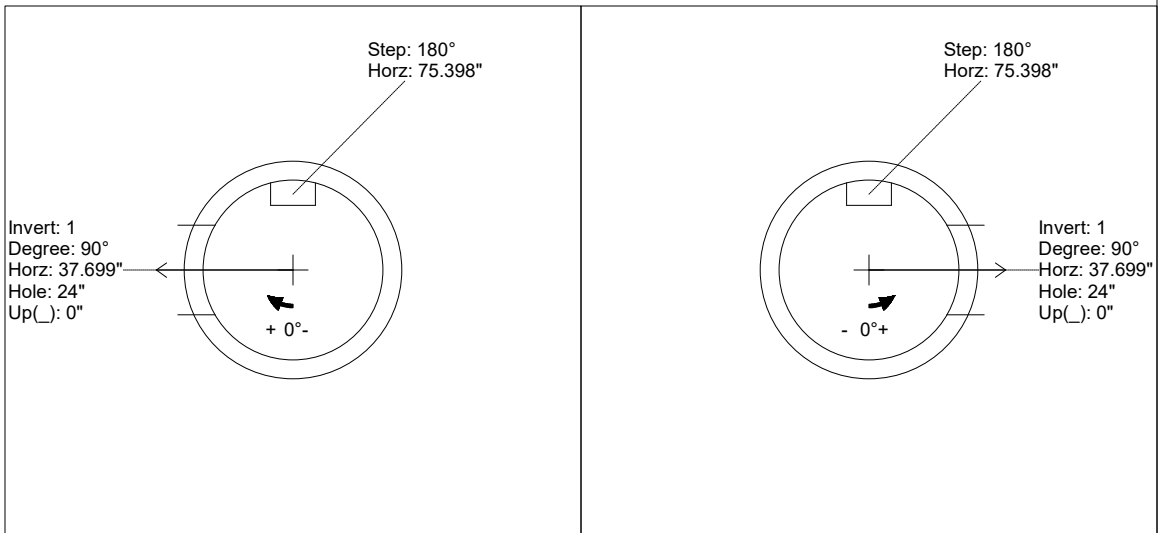

INSIDE WALL DIMENSIONS

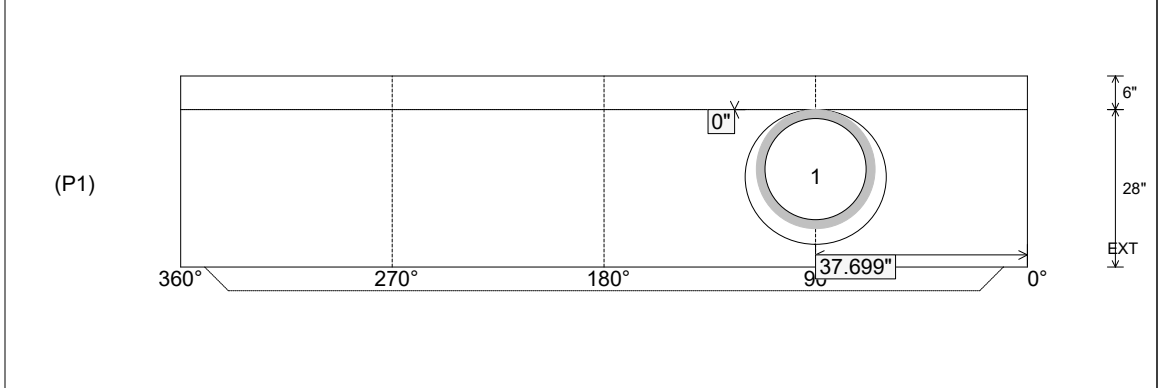

Coating (Int):  
 Coating (Ext):

Seam Up: Tongue  
 Seam Dn: n/a

Wall Thickness: 5"  
 Floor Height: 6"

Height (Int): 28"  
 Height (Ext): 34"

Weight (Net): 3136 lb  
 Volume (Net): 0.8cu.yd