

Job Name: 25-1267B Grocery Owensboro KY  
 Job Location: Owensboro, KY  
 Contractor: Winwater Hartford KY Co.

Plant: Beaver Dam

Tech: J. Coppage

9/18/2025 12:09:12 PM

PC: A. Chambers



**Structure ID: CB-C1**

**P1 MH048BA54**

**MH BASE**

- P3) 30" x 30" - CASTING HEIGHT - 4"
- P2) 48" - MH FLAT TOP w/30"x30" Hole - 12"
- P1) 48" - MH BASE - 54"
- 1) 48" - SGL 1"x14.5' Butyl (2x)
- 2) Hole - 26"
- 4) MH Step ML-10-TDS-NCR - 10"

- Structure Notes:**
1. JR HOE HOE-468 PROVIDED BY ICAST.
  2. PER ASTM C478 SPECIFICATIONS.
  3. CONCRETE = 4,000 PSI AT 28 DAYS.
  4. REINFORCING PER ASTM A615 (GRADE 60).
- TOP SLAB (As .62) #5 BARS AT 6" C.C.E.W..
  - RISER/WALLS (As .12)
  - FLOOR (As .31) #5 BARS AT 12" C.C.E.W.

Structure Total: 5986 lb

Rim: 397.25' Rim to Invert: 5.83' Slack: 2.46" Sump: 2.5" Step Position: 175°

Position	Elev	Angle	Ext. (cw)	Pipe	Pipe OD	Connector	Hole	Horz Size	Up ( )	Offset
Invert 1	391.42'	270°	136.659"	18" RCP B WALL	23"	Hole 26	26"	27.476"	0"	0"
Invert 2	391.42'	80°	40.492"	18" RCP B WALL	23"	Hole 26	26"	27.476"	0"	0"
Invert 3										
Invert 4										
Invert 5										
Invert 6										
Invert 7										
Invert 8										

RIGHT-SIDE UP VIEW (int. dimensions)

UPSIDE-DOWN VIEW (int. dimensions)

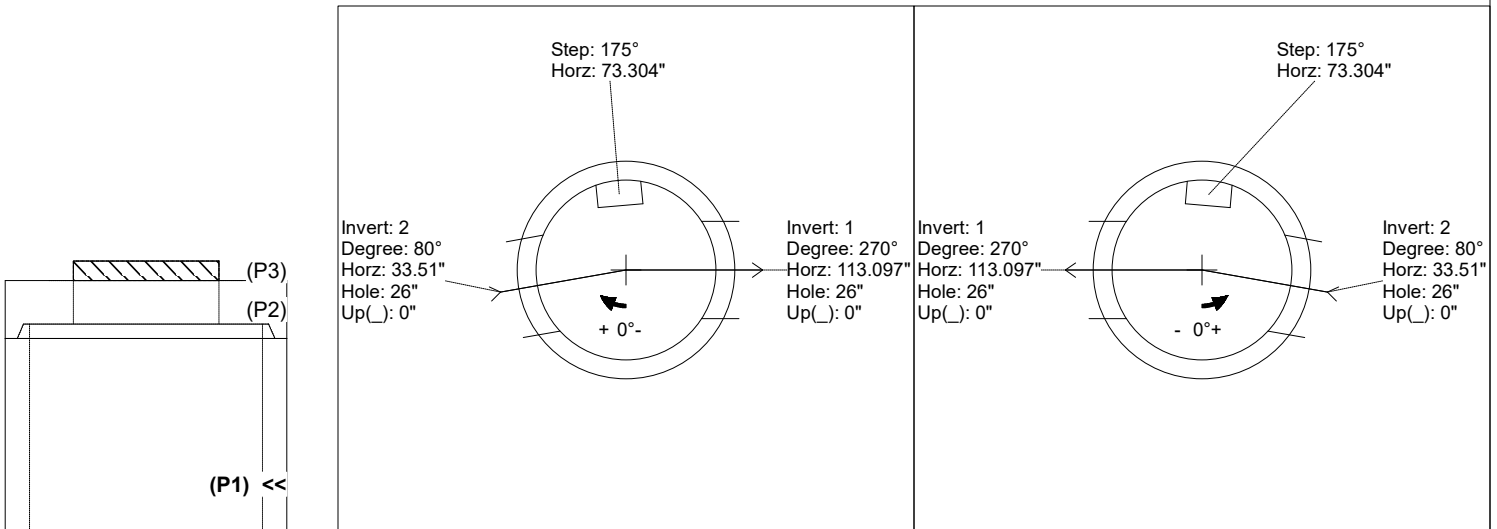

INSIDE WALL DIMENSIONS

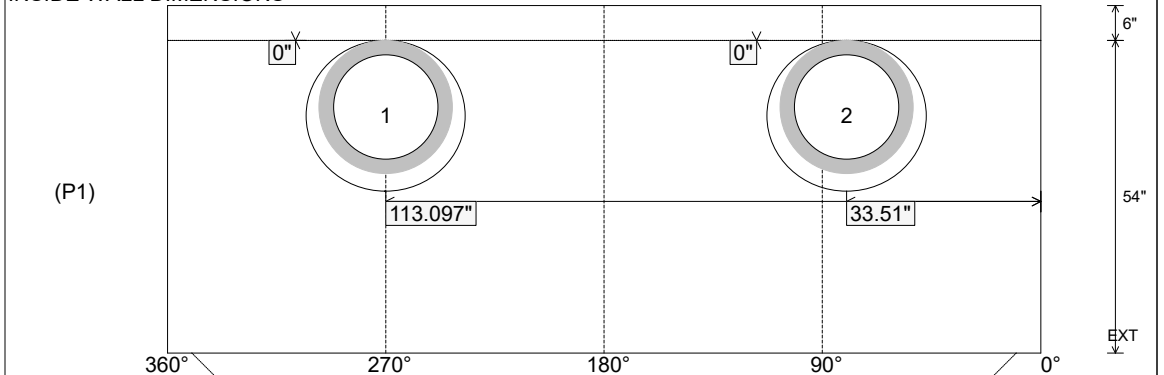

Coating (Int): Coating (Ext):	Seam Up: Tongue Seam Dn: n/a	Wall Thickness: 5" Floor Height: 6"	Height (Int): 54" Height (Ext): 60"	Weight (Net): 4636 lb Volume (Net): 1.18cu.yd
----------------------------------	---------------------------------	--	--	--