

Job Name: 25-1267B Grocery Owensboro KY
 Job Location: Owensboro, KY
 Contractor: Winwater Hartford KY Co.

Plant: Beaver Dam

Tech: J. Coppage

9/18/2025 12:09:07 PM

PC: A. Chambers



Structure ID: CB-A5.2

P1 MH060BAVF

MH BASE Custom Ht

- P3) 30" x 30" - CASTING HEIGHT - 4"
- P2) 60" - MH FLAT TOP SPEC. HT. (6") w/30"x30" Hole - 6"
- P1) 60" - MH BASE Custom Ht - 34"
- 1) 60" - SGL 1"x14.5' Butyl (2x)
- 2) DOGHOUSE INVRTD - 34"x34"
- 3) MH Step ML-10-TDS-NCR - 10"

- Structure Notes:**
1. JR HOE HOE-468 PROVIDED BY ICAST.
 2. PER ASTM C478 SPECIFICATIONS.
 3. CONCRETE = 4,000 PSI AT 28 DAYS.
 4. REINFORCING PER ASTM A615 (GRADE 60).
 - TOP SLAB (As .62) #5 BARS AT 6" C.C.E.W..
 - RISER/WALLS (As .18)
 - FLOOR (As .37) #5 BARS AT 10" C.C.E.W.

Structure Total: 6786 lb

Rim: 402.8' Rim to Invert: 3.58' Slack: 1.96' Sump: 3' Step Position: 180°

Position	Elev	Angle	Ext. (cw)	Pipe	Pipe OD	Connector	Hole	Horz Size	Up ()	Offset
Invert 1	399.22'	90°	56.549"	24" RCP B WALL	30"	DOGHOUSE INVRTD 34"x34"	34" x 34"	36.147"	0"	0"
Invert 2	399.22'	270°	169.646"	24" RCP B WALL	30"	DOGHOUSE INVRTD 34"x34"	34" x 34"	36.147"	0"	0"
Invert 3										
Invert 4										
Invert 5										
Invert 6										
Invert 7										
Invert 8										

RIGHT-SIDE UP VIEW (int. dimensions)

UPSIDE-DOWN VIEW (int. dimensions)

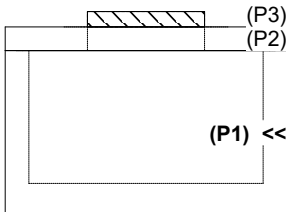
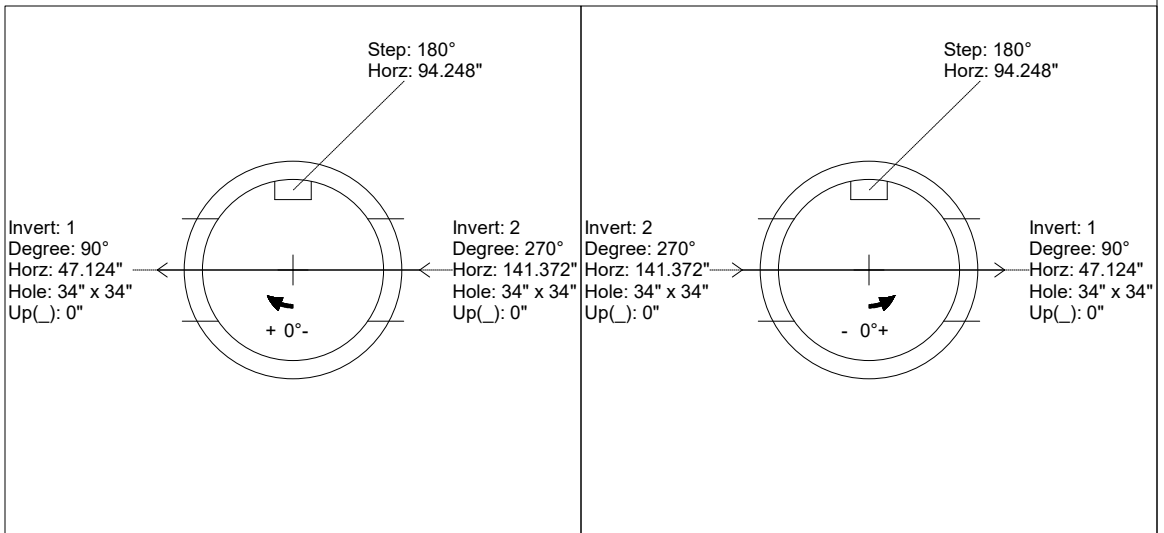

INSIDE WALL DIMENSIONS

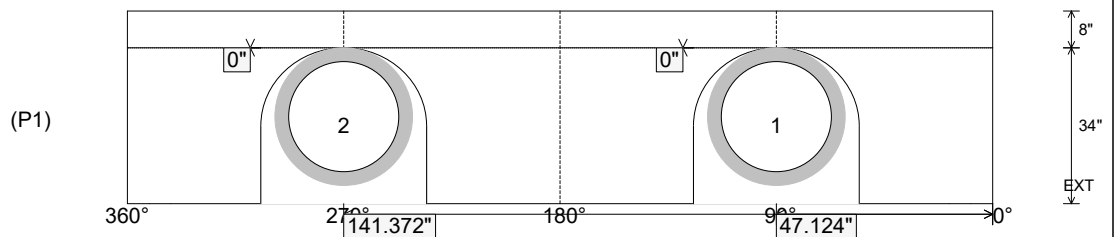

Coating (Int):
Coating (Ext):

Seam Up: Flat
Seam Dn: n/a

Wall Thickness: 6"
Floor Height: 8"

Height (Int): 34"
Height (Ext): 42"

Weight (Net): 5189 lb
Volume (Net): 1.32cu.yd