

THIS DRAWING IS INTENDED TO BE PRINTED IN COLOR.

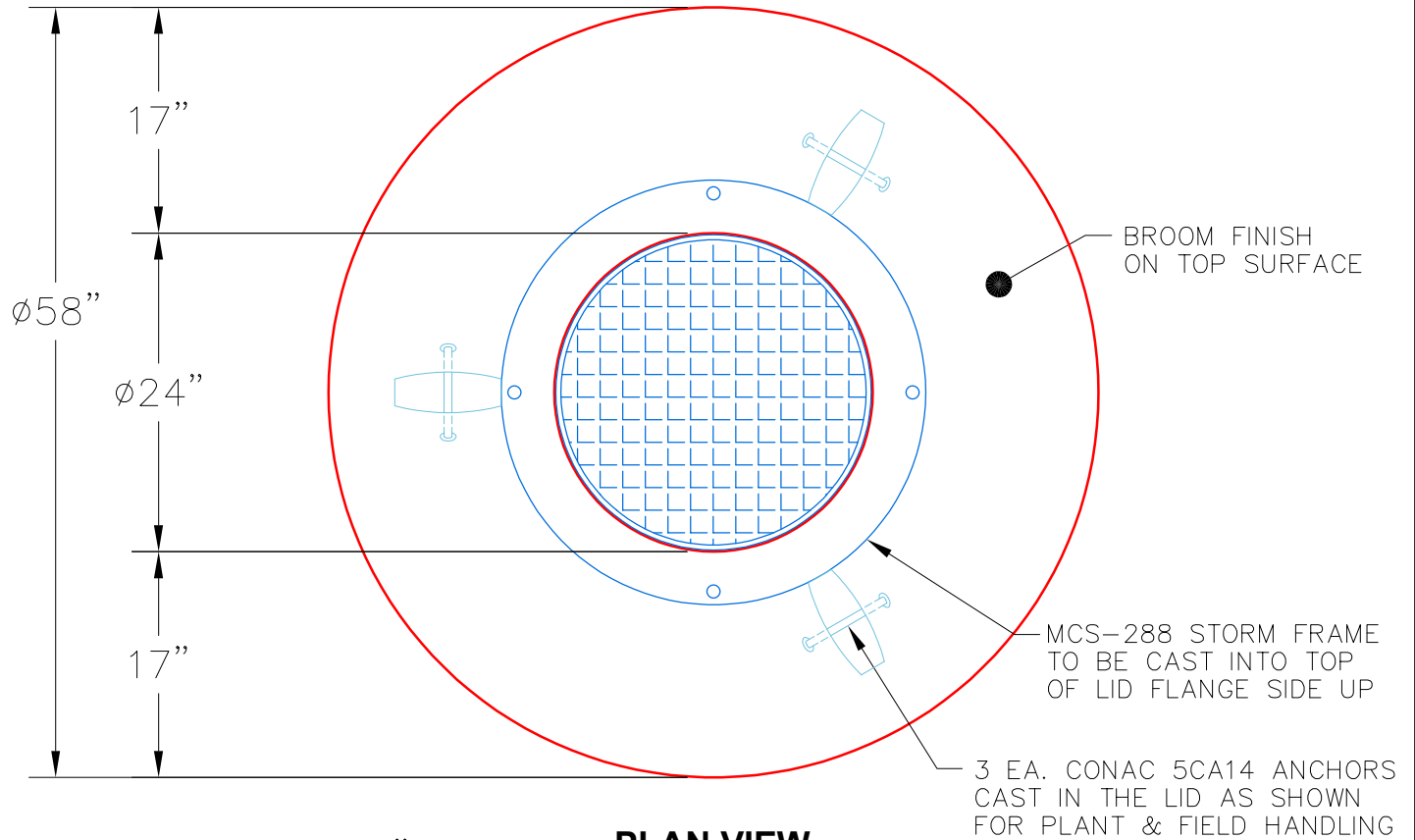

PLAN VIEW

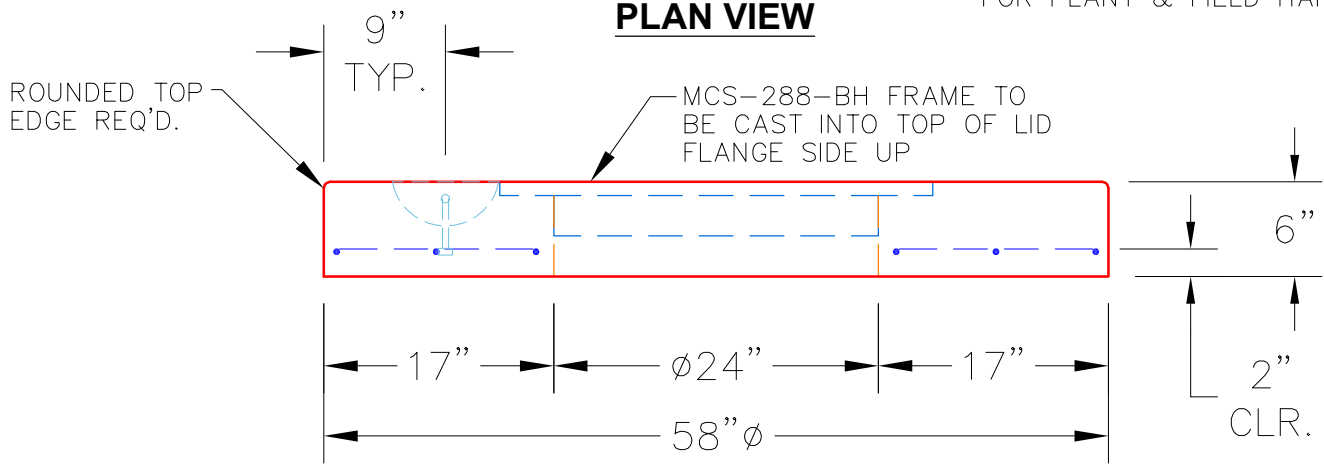

FRONT VIEW

NOTES:

1. MANUFACTURED TO ASTM C-478 (LATEST REVISION).
2. CONCRETE: 5,000 PSI AT 28 DAYS.
3. REINFORCING: #4 @10" O.C. E.W.(GRADE 60).
4. WEIGHT: 1,072 LBS.
5. JR HOE MCS-288 STORM BY ICAS.
6. MCS-288 STORM FRAME TO BE CAST INTO TOP SLAB FLANGE SIDE UP.

| | | | | | |
|--|--|------------------------------|---|---------------------|------------|
| PRODUCTION WORK ORDER | | PRODUCT I.D.: MH048LD06SP | DESCRIPTION: 48"ø X 6" MANHOLE TOP SLAB W/ FRAME CAST IN | | |
|  | QUALITY CONTROL CHECKLIST | PRODUCT VIEW: RIGHT SIDE UP | CUSTOMER: WINWATER HARTFORD KY CO. | | |
| | <input type="checkbox"/> ALL DIMENSIONS CORRECT. | PLANT: BEAVER DAM, KY. | PROJECT: GROCERY OWENSBORO KY | | |
| | <input type="checkbox"/> ILIFTING ANCHORS INSTALLED. | WEIGHT: 1,072 LBS. | STRUCTURE: CB-A3.1 | | |
| | <input type="checkbox"/> FRAME LOCATION CORRECT. | TOP SECTION JOINT: N/A | QUOTE/SALES ORDER NO: 25-1267B | | |
| | <input type="checkbox"/> REINFORCING CORRECT. | BASE SECTION JOINT: N/A | PC: A. CHAMBERS | DRAWING: J. COPPAGE | |
| | <input type="checkbox"/> FINISH ON SLAB SURFACE UNIFORM. | QC CHECK INITIALS: | DATE: 9/18/24 | SCALE: NTS | PG. 1 of 1 |
| <input type="checkbox"/> OUTSIDE TOP EDGE TROWELLED. | | | | | |
| <input type="checkbox"/> JOINT INSTALLED IF NECESSARY. | | | | | |