

Job Name: 25-1233 Southwire Co. East Expansion  
 Job Location: Hawesville, KY 42348  
 Contractor: Hodskins Services

Plant: Beaver Dam  
 6/5/2025 10:20:38 AM

Tech: J. Horsley  
 PC: A. Chambers



**Structure ID: SAN. MH A-5 (48in) LN.A 13+89**

**P3 MH048CN24**

**ECC CONE w/ 24" HOLE F/G**

P4) 24" - CASTING HEIGHT - 7"	0 lb
P3) 48" - ECC CONE w/ 24" HOLE F/G - 24"	1550 lb
P2) 48" - MH RISER T/G - 48"	3353 lb
P1) 48" - MH BASE T/n - 24"	2911 lb
1) JOINT WRAP - 0.065"x6"x50' CONSEAL CS212	0 lb
1) JOINT WRAP PRIMER - CONSEAL CS-75 (1 gal.)	0 lb
1) 48" - SAN. INV. CHANNEL - FULL HEIGHT	1440 lb
1) CASTING - HOE MC-315 F/C Sanitary	258 lb
2) 48" - DBL 1"x14.5' Butyl (2x)	0 lb
1) PSX - 12-08 NYLO	8 lb
1) PSX - 12-06 NYLO	8 lb
8) MH Step ML-10-TDS-NCR - 10"	0 lb
Structure Total:	9528 lb

Structure Notes:  
 1. PER ASTM C478 SPECIFICATIONS.  
 2. CONCRETE = 4,000 PSI AT 28 DAYS.  
 3. CASTING (HOE MC-315) SHIPPED LOOSE.

REINFORCING PER ASTM A615 (GRADE 60).  
 - CONE (As .12)  
 - RISER (As .12)  
 - FLOOR (As .31) #5 BARS AT 12" C.C.E.W.

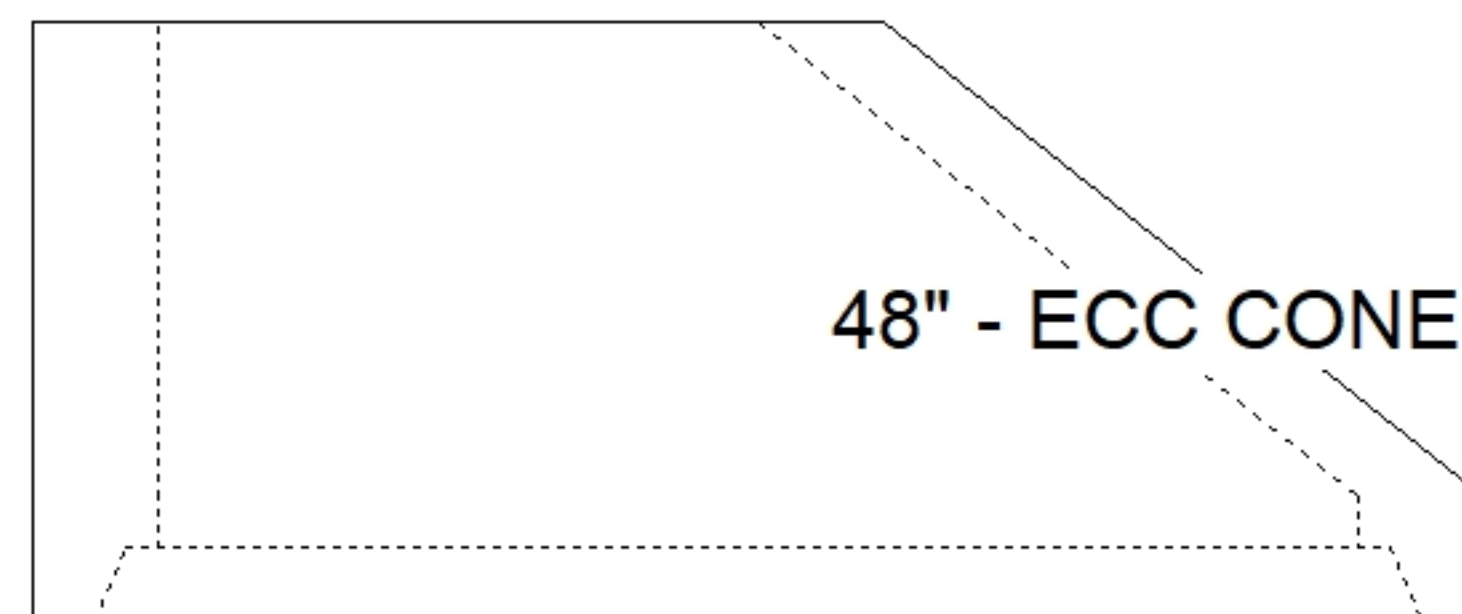
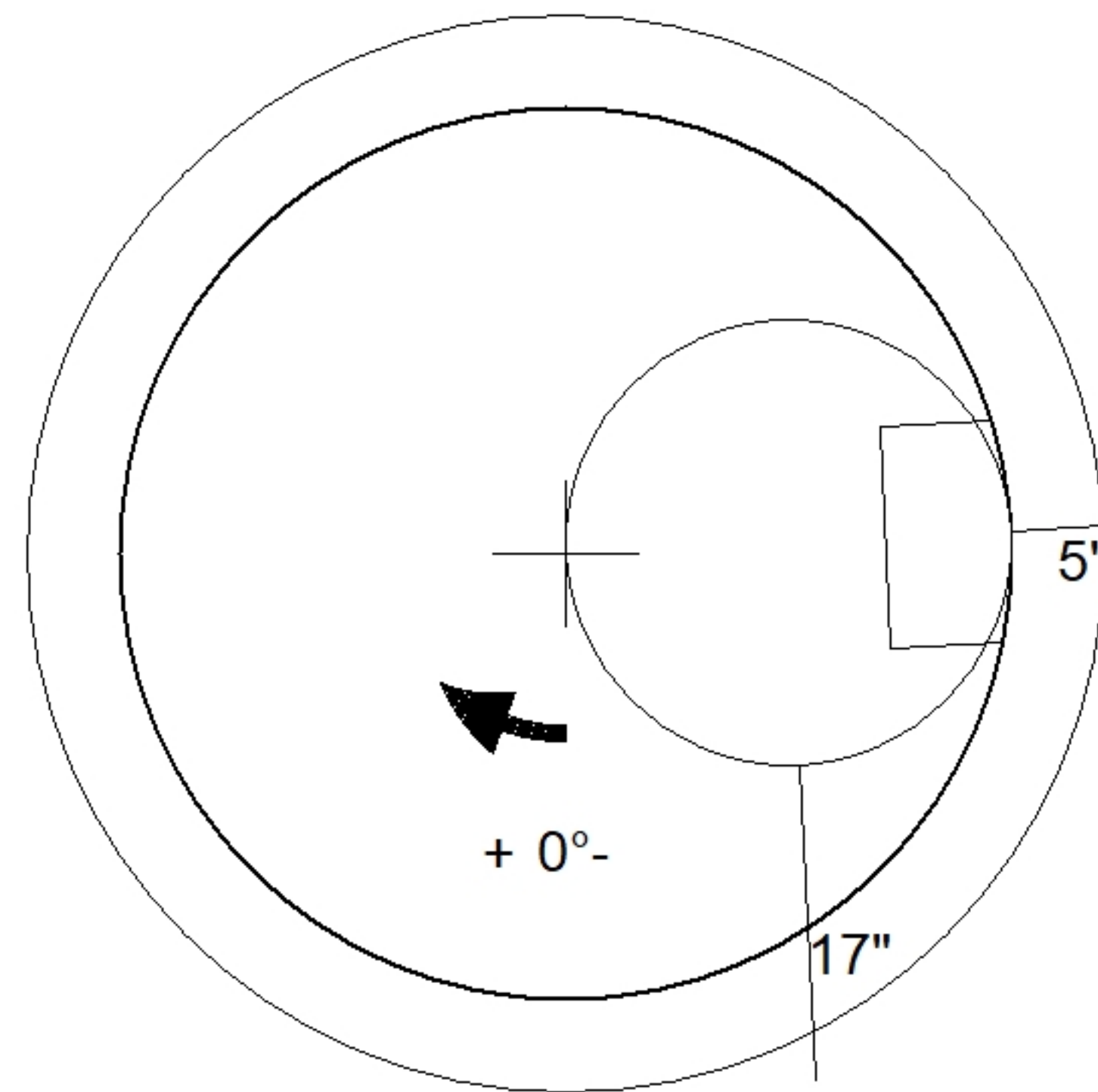

48" - ECC CONE w/ 24" HOLE F/G - 24" - (P3)

Coating (Int): Coating (Ext):	Seam Up: Flat Seam Dn: Groove	Wall Thickness: 5"	Height (Ext): 24"	Weight (Net): 1550 lb Volume (Net): 0.33cu.yd
----------------------------------	----------------------------------	--------------------	-------------------	--