

Job Name: 25-1172 - Midland Farms
 Job Location: Somerset, KY 45203
 Contractor: Weddle Enterprises, Inc

Plant: 100

Tech: J. Horsley - F

12/13/2025 11:42:37 AM

PC: C. Goff



Structure ID: SSMH 2

P1 MH048BA24

MH BASE T/n

P3) 24" - CASTING HEIGHT - 7"	0 lb
P2) 48" - ECC CONE w/ 24" HOLE F/G - 30"	2050 lb
P1) 48" - MH BASE T/n - 24"	2911 lb
1) 48" - MH INVERT CHANNEL - FULL HEIGHT	1440 lb
1) JOINT WRAP - 0.065"x6"x50' CONSEAL CS212	0 lb
1) JOINT WRAP PRIMER - CONSEAL CS-75 (1 gal.)	0 lb
1) 48" - Conseal CS-102 1.00" (Double)	0 lb
1) PSX - 12-08 NYLO	8 lb
1) PSX - 12-06 NYLO	8 lb
1) MH Step ML-10-TDS-NCR - 10"	0 lb
Structure Total:	6417 lb

Structure Notes:
 1. PER ASTM C-478 SPECIFICATIONS
 2. CONCRETE: 4,000 PSI AT 28 DAYS
 3. REINFORCEMENT: PER ASTM A615
 4. STEPS AT 0 DEGREES
 5. INVERT CHANNEL REQUIRED
 6. CASTING SUPPLIED BY OTHERS (7" FRAME & SOLID COVER)

Rim: 952.1' Rim to Invert: 5' Slack: 1" Sump: 2" Step Position: 0°

Position	Elev	Angle	Ext. (cw)	Pipe	Pipe OD	Connector	Hole	Horz Size	Up ()	Offset
Invert 1	947.1'	0°	0"	8" PVC SDR35	8.5"	PSX 12-08 NYLO	12"	12.129"	0"	0"
Invert 2	947.2'	90°	45.553"	6" PVC SDR35	6.25"	PSX 12-06 NYLO	12"	12.129"	0.2"	0"
Invert 3										
Invert 4										
Invert 5										
Invert 6										
Invert 7										
Invert 8										

RIGHT-SIDE UP VIEW (int. dimensions)

UPSIDE-DOWN VIEW (int. dimensions)

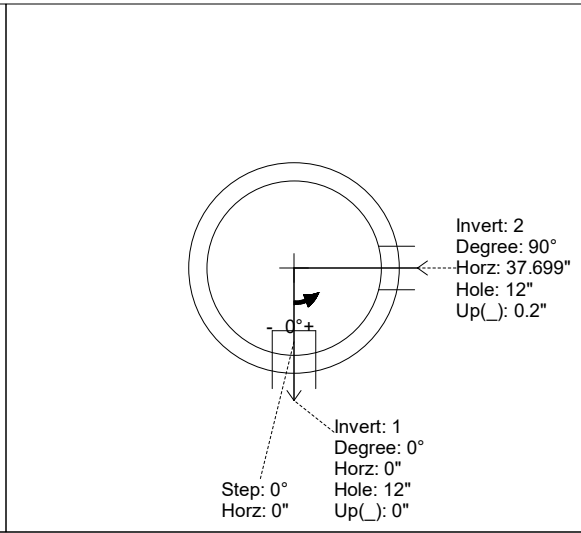
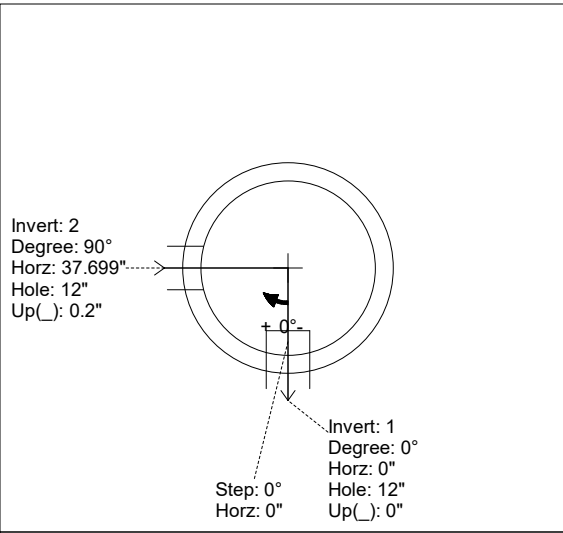
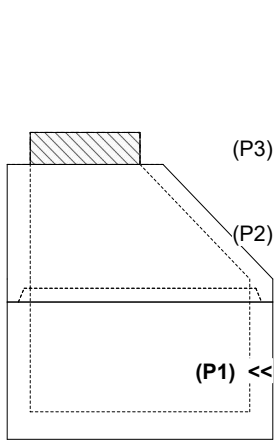

INSIDE WALL DIMENSIONS

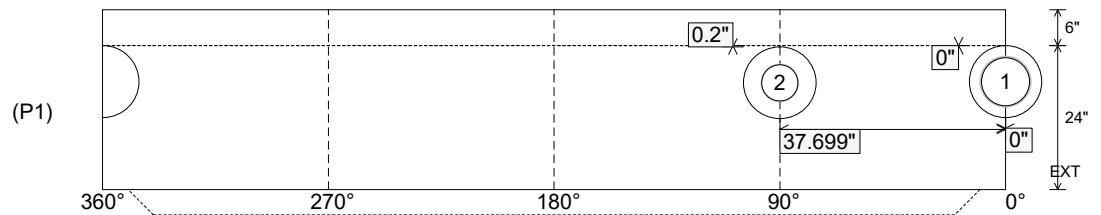

Coating (Int):
 Coating (Ext):

Seam Up: Tongue
 Seam Dn: n/a

Wall Thickness: 5"
 Floor Height: 6"

Height (Int): 24"
 Height (Ext): 30"

Weight (Net): 2911 lb
 Volume (Net): 0.74cu.yd

Job Name: 25-1172 - Midland Farms
 Job Location: Somerset, KY 45203
 Contractor: Weddle Enterprises, Inc

Plant: 100

Tech: J. Horsley - F

12/13/2025 11:42:37 AM

PC: C. Goff



Structure ID: SSMH 2

P1 MH048BA24

MH BASE T/n

- P3) 24" - CASTING HEIGHT - 7" 0 lb
- P2) 48" - ECC CONE w/ 24" HOLE F/G - 30" 2050 lb
- P1) 48" - MH BASE T/n - 24" 2911 lb
- 1) 48" - MH INVERT CHANNEL - FULL HEIGHT 1440 lb
- 1) JOINT WRAP - 0.065"x6"x50' CONSEAL CS212 0 lb
- 1) JOINT WRAP PRIMER - CONSEAL CS-75 (1 gal.) 0 lb
- 1) 48" - Conseal CS-102 1.00" (Double) 0 lb
- 1) PSX - 12-08 NYLO 8 lb
- 1) PSX - 12-06 NYLO 8 lb
- 1) MH Step ML-10-TDS-NCR - 10" 0 lb

Structure Total: 6417 lb

- Structure Notes:**
1. PER ASTM C-478 SPECIFICATIONS
 2. CONCRETE: 4,000 PSI AT 28 DAYS
 3. REINFORCEMENT: PER ASTM A615
 4. STEPS AT 0 DEGREES
 5. INVERT CHANNEL REQUIRED
 6. CASTING SUPPLIED BY OTHERS (7" FRAME & SOLID COVER)

Rim: 952.1' Rim to Invert: 5' Slack: 1" Sump: 2" Step Position: 0°

Position	Elev	Angle	Ext. (cw)	Pipe	Pipe OD	Connector	Hole	Horz Size	Up ()	Offset
Invert 1	947.1'	0°	0"	8" PVC SDR35	8.5"	PSX 12-08 NYLO	12"	12.129"	0"	0"
Invert 2	947.2'	90°	45.553"	6" PVC SDR35	6.25"	PSX 12-06 NYLO	12"	12.129"	0.2"	0"
Invert 3										
Invert 4										
Invert 5										
Invert 6										
Invert 7										
Invert 8										

RIGHT-SIDE UP VIEW (int. dimensions)

UPSIDE-DOWN VIEW (int. dimensions)

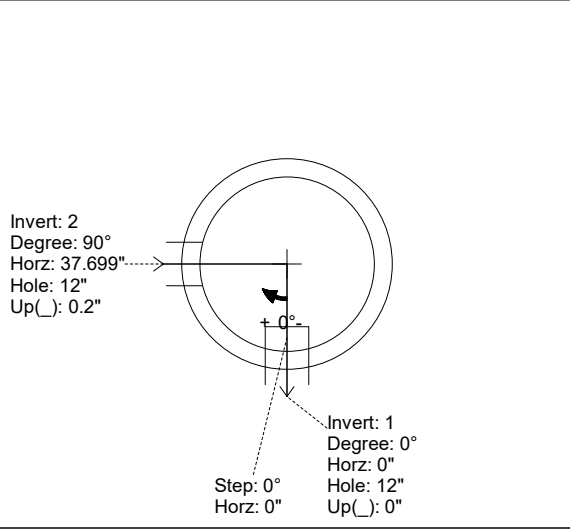
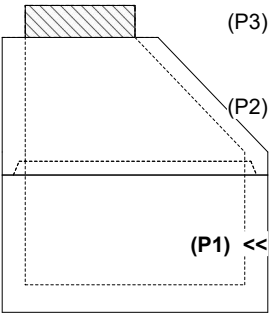

INVERT CHANNEL
DRAWING

INSIDE WALL DIMENSIONS

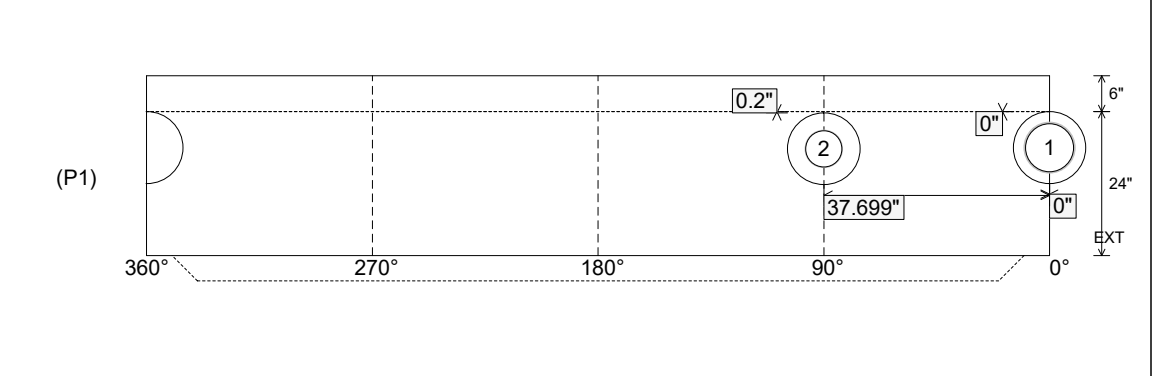

Coating (Int): Coating (Ext):	Seam Up: Tongue Seam Dn: n/a	Wall Thickness: 5" Floor Height: 6"	Height (Int): 24" Height (Ext): 30"	Weight (Net): 2911 lb Volume (Net): 0.74cu.yd
----------------------------------	---------------------------------	--	--	--