

Job Name: 25-1172 - Midland Farms
Job Location: Somerset, KY 45203
Contractor: Weddle Enterprises, Inc

PC: C. Goff
 TECH: J. Horsley - F
 Plant: 100



Structure ID: **CB 5**
 Spec: Storm
 Type: STM.MH (Recessed pipe)
 Size: 48"

Rim: 950.2'
 Invert: 946.2'
 Rim to Invert: 4'

Sump: 0"
 Floor (Top): 946.2'
 Floor Height: 6"

Floor (Bot): 945.7'
 Overall Height: 4.458'
 Slack: 0.5"

Structure Notes:

1. PER ASTM C-478 SPECIFICATIONS
2. CONCRETE: 4,000 PSI AT 28 DAYS
3. REINFORCEMENT: PER ASTM A615
4. NO STEPS & NO INVERT CHANNEL
5. CASTING SUPPLIED BY OTHERS (HOE 580-A FRAME & GRATE)

STRUCTURE SUMMARY:

- P3) 18" x 36" - CASTING HEIGHT - 5.5" 0 lb
- P2) 48" - MH FLAT TOP w/18"x36" Hole F/G - 12" 2008 lb
- P1) 48" - MH BASE T/n - 30" 3155 lb
- 1) 48" - Conseal CS-102 1.00" 0 lb
- 1) 18" x 36" - Conseal CS-102 1.00" 0 lb
- 2) Hole - 20 0 lb
- Structure Total: 5163 lb**

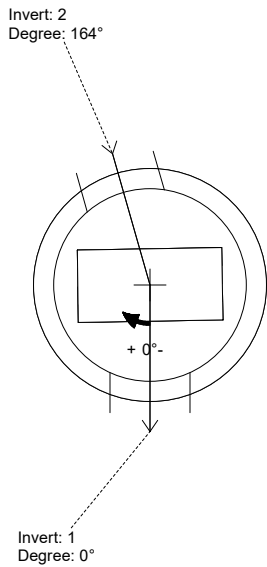

Position	Elev	Angle	Pipe	Pipe OD	Hole	Connector	Up (L)	Ref
Rim	950.2'							
Reducer								
Invert 1	946.2'	0°	15" HDPE	17.6"	20"	Hole 20	-1.3"	P1
Invert 2	946.2'	164°	15" HDPE	17.6"	20"	Hole 20	-1.3"	P1
Invert 3								
Invert 4								
Invert 5								
Invert 6								
Invert 7								
Invert 8								

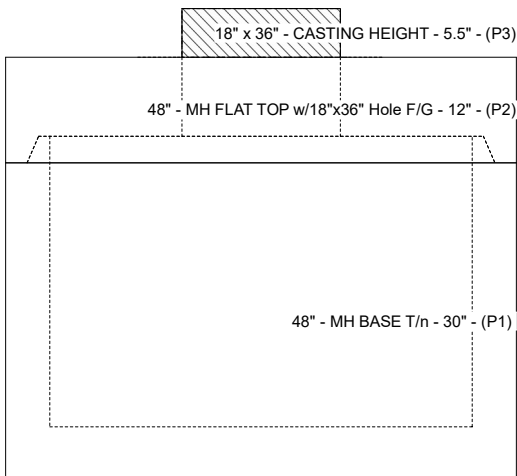

Cast (Int. Dim.) - Interior Dimensions

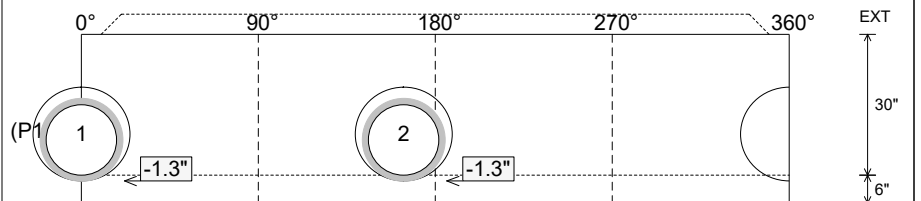

Submittal Drawing
 12/15/2025 12:23:13 PM

SUBMITTAL
 APPROVED BY: