

Job Name: 25-1172 - Midland Farms  
 Job Location: Somerset, KY 45203  
 Contractor: Weddle Enterprises, Inc

Plant: 100

Tech: J. Horsley - F

12/13/2025 11:42:35 AM

PC: C. Goff



**Structure ID: CB 4**

**P1 MH048BA24**

**MH BASE T/n**

- P4) 24" - CASTING HEIGHT - 7"
- P3) 24" - GRADE RING F/F - 4"
- P2) 48" - MH FLAT TOP w/ 24" ECC Hole F/G - 12"
- P1) 48" - MH BASE T/n - 24"
- 1) 48" - Conseal CS-102 1.00"
- 1) Hole - 20
- 2) Hole - 16

0 lb  
 270 lb  
 1561 lb  
 2700 lb  
 0 lb  
 0 lb  
 0 lb  
 -----  
 4531 lb

Structure Total:

- Structure Notes:**
1. PER ASTM C-478 SPECIFICATIONS
  2. CONCRETE: 4,000 PSI AT 28 DAYS
  3. REINFORCEMENT: PER ASTM A615
  4. NO STEPS & NO INVERT CHANNEL
  5. CASTING SUPPLIED BY OTHERS (7" FRAME & SOLID COVER)

Rim: 951.3' Rim to Invert: 4' Slack: 1" Sump: 0" Step Position:

Position	Elev	Angle	Ext. (cw)	Pipe	Pipe OD	Connector	Hole	Horz Size	Up ( )	Offset
Invert 1	947.3'	0°	0"	15" HDPE	17.6"	Hole 20	20"	20.629"	-1.3"	0"
Invert 2	947.3'	104°	52.639"	12" HDPE	14.5"	Hole 16	16"	16.312"	-1.25"	0"
Invert 3	947.3'	194°	98.192"	12" HDPE	14.5"	Hole 16	16"	16.312"	-1.25"	0"
Invert 4										
Invert 5										
Invert 6										
Invert 7										
Invert 8										

RIGHT-SIDE UP VIEW (int. dimensions)

UPSIDE-DOWN VIEW (int. dimensions)

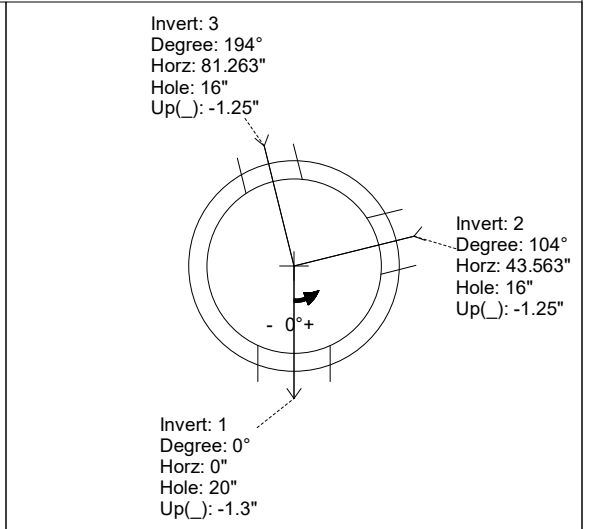
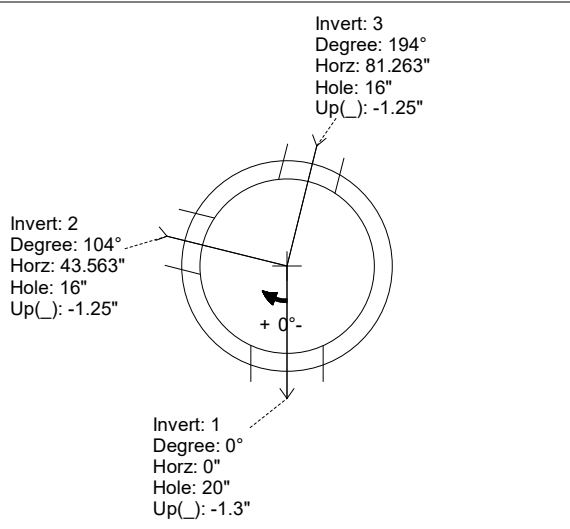
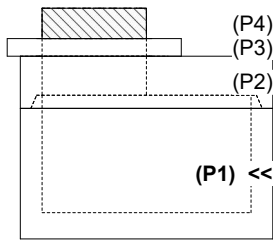

INSIDE WALL DIMENSIONS

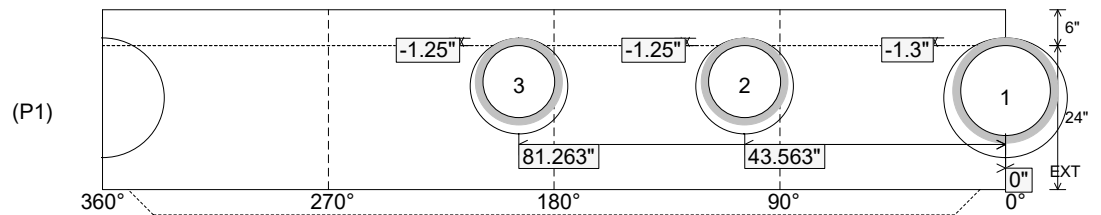

Coating (Int):  
 Coating (Ext):

Seam Up: Tongue  
 Seam Dn: n/a

Wall Thickness: 5"  
 Floor Height: 6"

Height (Int): 24"  
 Height (Ext): 30"

Weight (Net): 2700 lb  
 Volume (Net): 0.69cu.yd