

**Job Name: 25-1172 - Midland Farms**  
**Job Location: Somerset, KY 45203**  
**Contractor: Weddle Enterprises, Inc**

PC: C. Goff  
 TECH: J. Horsley - F  
 Plant: 100



Structure ID: **CB 3**

Spec: Storm  
 Type: STM.MH (Recessed pipe)  
 Size: 48"

Rim: 947.75'  
 Invert: 941.5'  
 Rim to Invert: 6.25'

Sump: 0"  
 Floor (Top): 941.5'  
 Floor Height: 6"

Floor (Bot): 941'  
 Overall Height: 6.708'  
 Slack: 0.5"

**Structure Notes:**

1. PER ASTM C-478 SPECIFICATIONS
2. CONCRETE: 4,000 PSI AT 28 DAYS
3. REINFORCEMENT: PER ASTM A615
4. STEPS AT 85 DEGREES
5. NO INVERT CHANNEL
6. CASTING SUPPLIED BY OTHERS (HOE 580-A FRAME & GRATE)

**STRUCTURE SUMMARY:**

- P3) 18" x 36" - CASTING HEIGHT - 5.5" 0 lb
- P2) 48" - MH FLAT TOP w/18"x36" Hole F/G - 12" 2008 lb
- P1) 48" - MH BASE Custom Ht T/n - 57" 4918 lb
- 1) 48" - Conseal CS-102 1.00" 0 lb
- 1) 18" x 36" - Conseal CS-102 1.00" 0 lb
- 2) Hole - 24 0 lb
- 5) MH Step ML-10-TDS-NCR - 10" 0 lb
- 
- Structure Total: 6926 lb

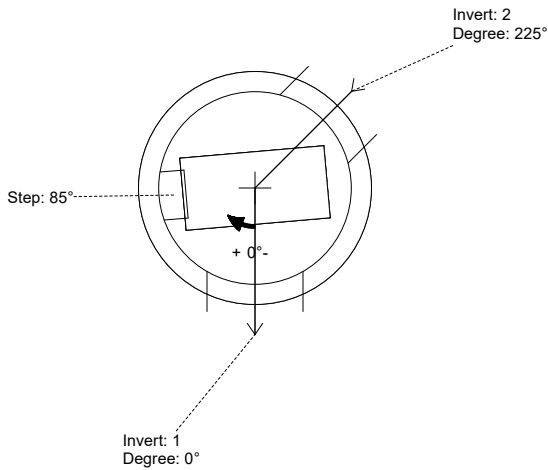

Position	Elev	Angle	Pipe	Pipe OD	Hole	Connector	Up (L)	Ref
Rim	947.75'							
Reducer								
Invert 1	941.5'	0°	18" HDPE	21.2"	24"	Hole 24	-1.6"	P1
Invert 2	941.5'	225°	18" HDPE	21.2"	24"	Hole 24	-1.6"	P1
Invert 3								
Invert 4								
Invert 5								
Invert 6								
Invert 7								
Invert 8								

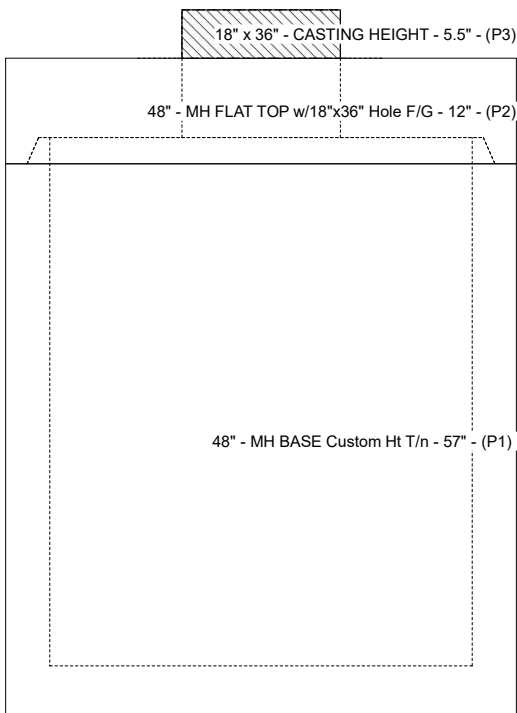

**Cast (Int. Dim.) - Interior Dimensions**

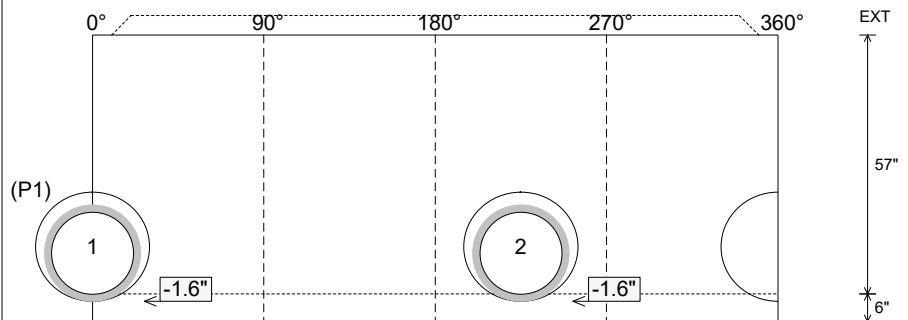

Submittal Drawing  
 12/15/2025 12:23:12 PM

SUBMITTAL  
 APPROVED BY: