

Job Name: 25-1172 - Midland Farms
 Job Location: Somerset, KY 45203
 Contractor: Weddle Enterprises, Inc

Plant: 100
 12/13/2025 11:43:25 AM

Tech: J. Horsley - F
 PC: C. Goff



Structure ID: CB 2

P2 MH048LD12-18x36 RECT

MH FLAT TOP w/18"x36" Hole F/G

- P3) 18" x 36" - CASTING HEIGHT - 5.5"
- P2) 48" - MH FLAT TOP w/18"x36" Hole F/G - 12"
- P1) 48" - MH BASE T/n - 30"
- 1) 48" - Conseal CS-102 1.00"
- 1) 18" x 36" - Conseal CS-102 1.00"
- 2) Hole - 24"

0 lb
 2008 lb
 3032 lb
 0 lb
 0 lb
 0 lb

 0 lb
 Structure Total: 5039 lb

- Structure Notes:**
1. PER ASTM C-478 SPECIFICATIONS
 2. CONCRETE: 4,000 PSI AT 28 DAYS
 3. REINFORCEMENT: PER ASTM A615
 4. NO STEPS & NO INVERT CHANNEL
 5. CASTING SUPPLIED BY OTHERS (HOE 580-A FRAME & GRATE)
 6. LIFTERS: 4 EA. WRA016 CONAC WIRE ROPE ANCHORS FOR PLANT & FIELD HANDLING

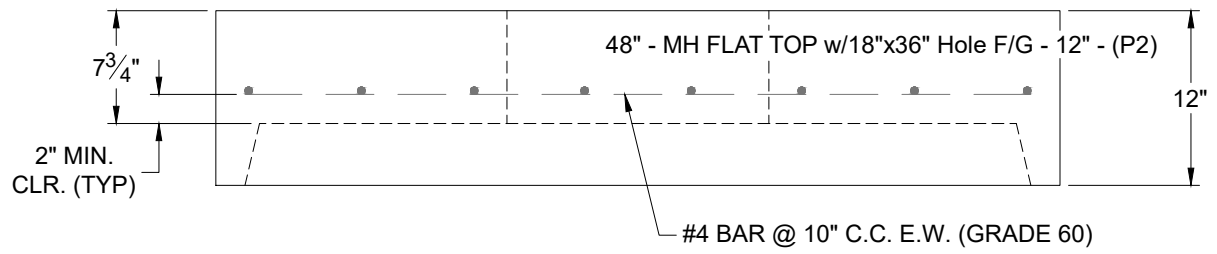
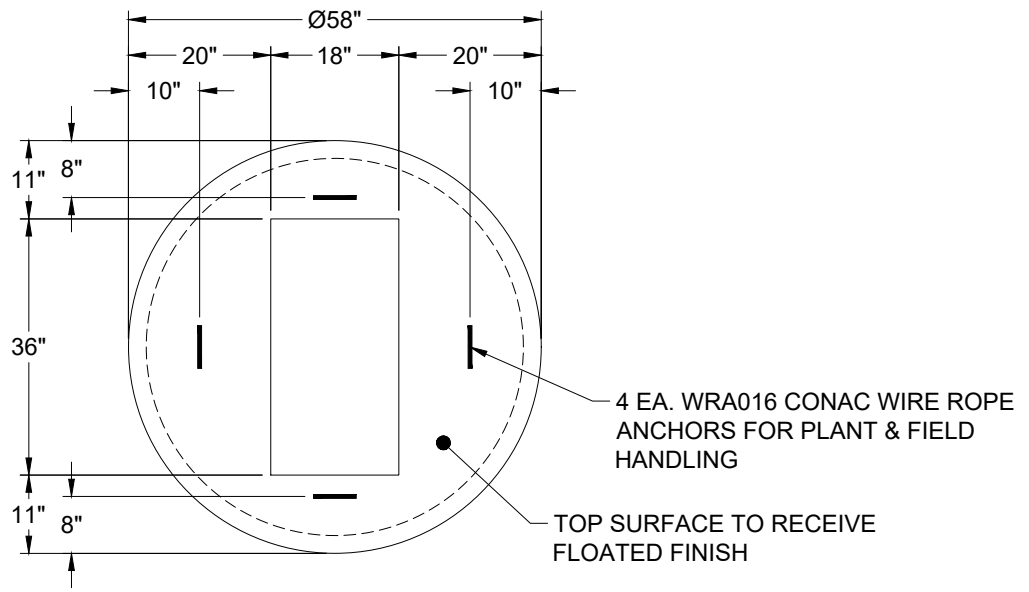

Coating (Int): Coating (Ext):	Seam Up: Flat Seam Dn: Groove	Wall Thickness: 5"	Height (Ext): 12"	Weight (Net): 2008 lb Volume (Net): 0.51cu.yd
----------------------------------	----------------------------------	--------------------	-------------------	--