

Job Name: 25-1172 - Midland Farms
 Job Location: Somerset, KY 45203
 Contractor: Weddle Enterprises, Inc

Plant: 100

Tech: J. Horsley - F

12/13/2025 11:42:33 AM

PC: C. Goff



Structure ID: CB 1

P1 MH048BA30

MH BASE T/n

- P3) 18" x 36" - CASTING HEIGHT - 5.5"
- P2) 48" - MH FLAT TOP w/18"x36" Hole F/G - 12"
- P1) 48" - MH BASE T/n - 30"
- 1) 48" - Conseal CS-102 1.00"
- 1) 18" x 36" - Conseal CS-102 1.00"
- 1) Hole - 24
- 1) Hole - 20

0 lb
 2008 lb
 3093 lb
 0 lb
 0 lb
 0 lb
 0 lb

 0 lb
 Structure Total: 5101 lb

- Structure Notes:**
1. PER ASTM C-478 SPECIFICATIONS
 2. CONCRETE: 4,000 PSI AT 28 DAYS
 3. REINFORCEMENT: PER ASTM A615
 4. NO STEPS & NO INVERT CHANNEL
 5. CASTING SUPPLIED BY OTHERS (HOE 580-A FRAME & GRATE)

Rim: 949.5' Rim to Invert: 4' Slack: 0.5" Sump: 0" Step Position:

Position	Elev	Angle	Ext. (cw)	Pipe	Pipe OD	Connector	Hole	Horz Size	Up ()	Offset
Invert 1	945.5'	0°	0"	18" HDPE	21.2"	Hole 24	24"	25.133"	-1.6"	0"
Invert 2	945.5'	206°	104.266"	15" HDPE	17.6"	Hole 20	20"	20.629"	-1.3"	0"
Invert 3										
Invert 4										
Invert 5										
Invert 6										
Invert 7										
Invert 8										

RIGHT-SIDE UP VIEW (int. dimensions)

UPSIDE-DOWN VIEW (int. dimensions)

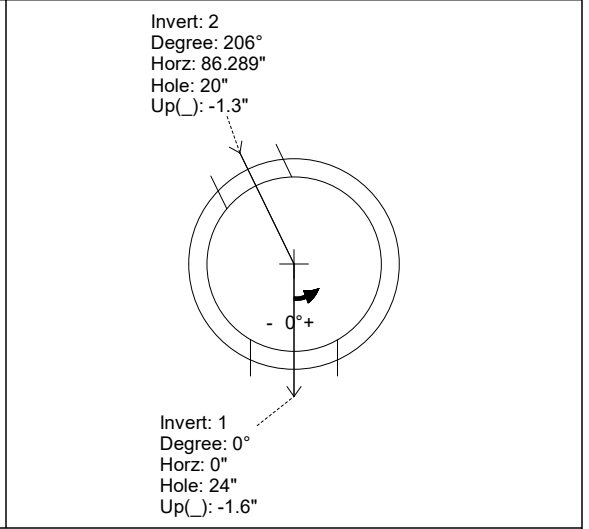
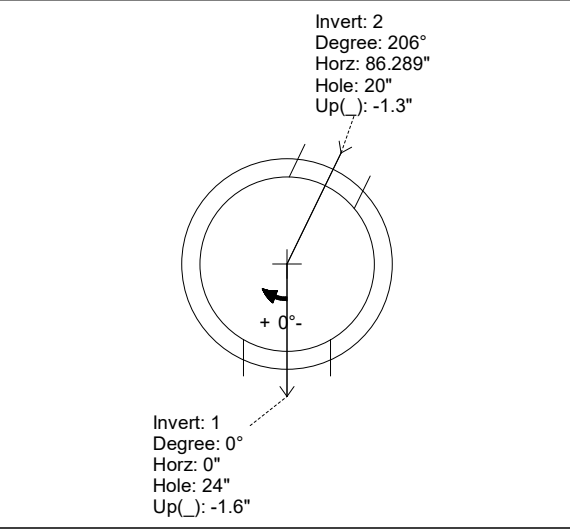
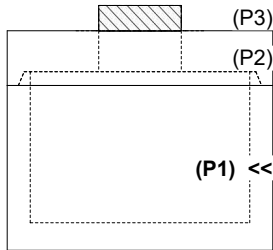

INSIDE WALL DIMENSIONS

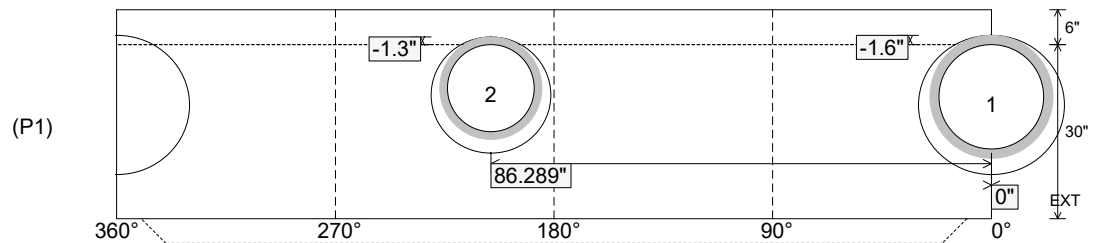

Coating (Int):
 Coating (Ext):

Seam Up: Tongue
 Seam Dn: n/a

Wall Thickness: 5"
 Floor Height: 6"

Height (Int): 30"
 Height (Ext): 36"

Weight (Net): 3093 lb
 Volume (Net): 0.79cu.yd