

Job Name: 25-1172 - Midland Farms
 Job Location: Somerset, KY 45203
 Contractor: Weddle Enterprises, Inc

Plant: 100

Tech: J. Horsley - F

12/16/2025 1:29:24 PM

PC: C. Goff



Structure ID: ARV 1

P2 MH048LD12ECC

MH FLAT TOP w/ 24" ECC Hole F/G

- P3) 24" - CASTING HEIGHT - 7"
- P2) 48" - MH FLAT TOP w/ 24" ECC Hole F/G - 12"
- P1) 48" - MH DH RISER Custom Ht T/F - 29"
- 1) JOINT WRAP - 0.065"x6"x50" CONSEAL CS212
- 1) JOINT WRAP PRIMER - CONSEAL CS-75 (1 gal.)
- 1) 48" - Conseal CS-102 1.00" (Double)
- 1) Hole - 0

0 lb
 1561 lb
 2026 lb
 0 lb
 0 lb
 0 lb
 0 lb

 0 lb
 Structure Total: 3587 lb

- Structure Notes:
1. PER ASTM C-478 SPECIFICATIONS
 2. CONCRETE: 4,000 PSI AT 28 DAYS
 3. REINFORCEMENT: #4 BAR @ 10" C.C. E.W. (GRADE 60) - 2" MIN. REBAR CLEARANCE (TYP)
 4. NO STEPS
 5. CASTING SUPPLIED BY OTHERS (7" FRAME & SOLID COVER)
 6. LIFTERS: 4 EA. WRA016 CONAC WIRE ROPE ANCHORS FOR PLANT & FIELD HANDLING

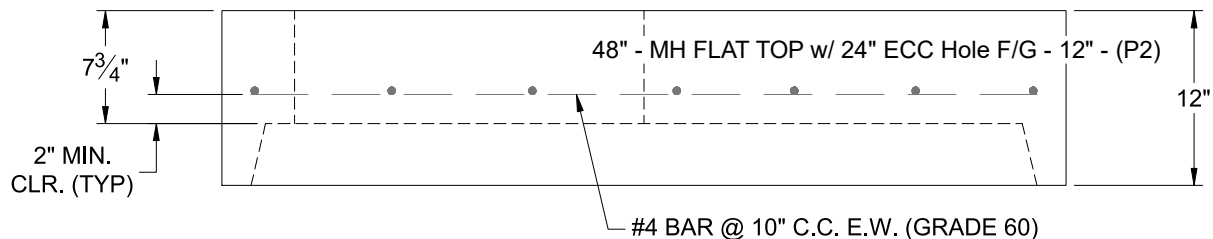
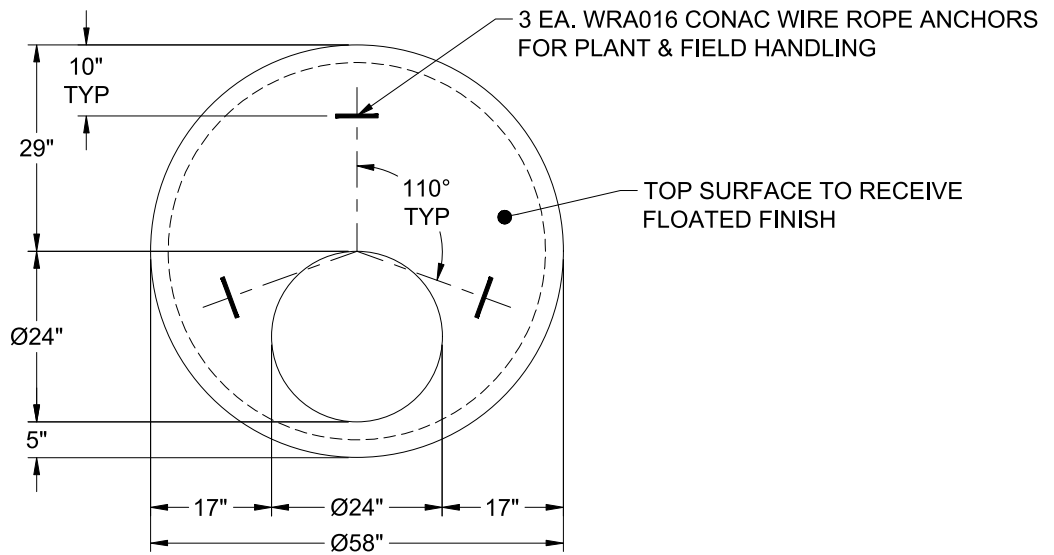

Coating (Int):
 Coating (Ext):

Seam Up: Flat
 Seam Dn: Groove

Wall Thickness: 5"

Height (Ext): 12"

Weight (Net): 1561 lb
 Volume (Net): 0.42cu.yd