

Job Name: 25-1145 - 7959 Poplar Creek
 Job Location: Nashville, TN 37221
 Contractor: Elite Constructors, Inc.

Plant: Beaver Dam, KY
 11/17/2025 11:34:02 AM

Tech: K. Cardwell
 PC: A. Chambers



Structure ID: MH-A5

P3 MH048CCN24CDARED

CON CONE w/24" HOLE, w/ConBlock-CDA Red F/G

P5) 24" - CASTING HEIGHT - 6"	0 lb
P4) 24" - GRADE RING w/ConBlock-CDA Red F/F - 3"	202 lb
P3) 48" - CON CONE w/24" HOLE, w/ConBlock-CDA Red F/G - 24"	1297 lb
P2) 48" - MH RISER w/ConBlock-CDA Red T/G - 36"	2515 lb
P1) 48" - MH BASE w/ConBlock-CDA Red T/n - 24"	2825 lb
1) JOINT WRAP PRIMER - CONSEAL CS-75 (1 gal.)	0 lb
1) JOINT WRAP - 0.065"x6"x50" CONSEAL CS212	0 lb
1) 48" - MH INVERT CHANNEL w/ConBlock-CDA Red - FULL HEIGHT	1440 lb
1) CASTING - JBS 1155 F/C SANITARY	250 lb
2) 48" - Conseal CS-102 1.00" (Double)	0 lb
1) Quik-Lok - QL-08-C	1 lb
3) PSX - 12-06 NYLO	24 lb
7) MH Step ML-10-TDS-NCR - 10"	0 lb
Structure Total:	8554 lb

Structure Notes:
 STATION: 18+40.62
 1. PER ASTM C-478 SPECS
 2. CONCRETE: 4,500 PSI AT 28 DAYS
 3. REINFORCEMENT: PER ASTM A615
 4. CONBLOCK CDA RED ADMIXTURE REQUIRED
 5. INVERT CHANNEL REQUIRED
 6. STEPS AT 63 DEGREES
 7. JBS 1155 FRAME & COVER "SANITARY" SUPPLIED BY ICAST

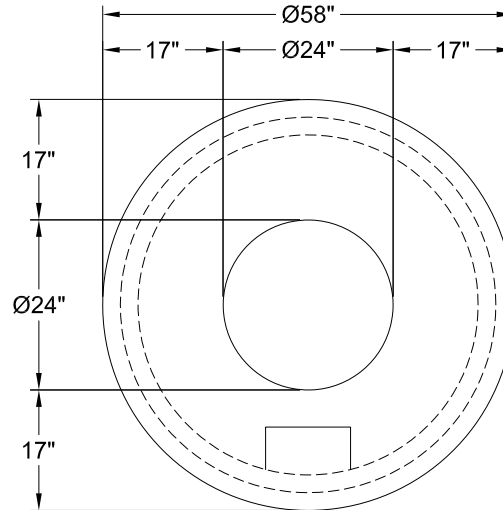

48" - CON CONE w/24" HOLE, w/ConBlock-CDA Red F/G - 24" - (P3)

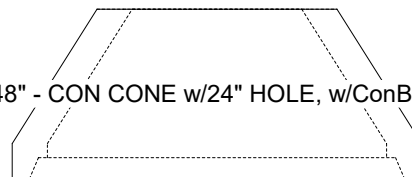

Coating (Int): Coating (Ext):	Seam Up: Flat Seam Dn: Groove	Wall Thickness: 5"	Height (Ext): 24"	Weight (Net): 1297 lb Volume (Net): 0.33cu.yd
----------------------------------	----------------------------------	--------------------	-------------------	--