

Job Name: 25-1145 - 7959 Poplar Creek
Job Location: Nashville, TN 37221
Contractor: Elite Constructors, Inc.

PC: A. Chambers
 TECH: K. Cardwell
 Plant: Beaver Dam, KY



Structure ID: **MH-A4**

Spec: Sanitary
 Type: SAN.MH w/ConBlock-CDA Red
 Size: 48"

Rim: 601.21'
 Invert: 593.4'
 Rim to Invert: 7.81'

Sump: 2"
 Floor (Top): 593.233'
 Floor Height: 6"

Floor (Bot): 592.733'
 Overall Height: 8.333'
 Slack: 1.72"

Structure Notes:

- STATION: 16+60.59
- 1. PER ASTM C-478 SPECS
- 2. CONCRETE: 4,500 PSI AT 28 DAYS
- 3. REINFORCEMENT: PER ASTM A615
- 4. CONBLOCK CDA RED ADMIXTURE REQUIRED
- 5. INVERT CHANNEL REQUIRED
- 6. STEPS AT 106 DEGREES
- 7. JBS 1155 FRAME & COVER "SANITARY" SUPPLIED BY ICAST

STRUCTURE SUMMARY:

- P5) 24" - CASTING HEIGHT - 6" 0 lb
 - P4) 24" - GRADE RING w/ConBlock-CDA Red F/F - 4" 270 lb
 - P3) 48" - CON CONE w/24" HOLE, w/ConBlock-CDA Red F/G - 24" 1297 lb
 - P2) 48" - MH RISER w/ConBlock-CDA Red T/G - 36" 2515 lb
 - P1) 48" - MH BASE w/ConBlock-CDA Red T/n - 24" 2921 lb
 - 1) JOINT WRAP PRIMER - CONSEAL CS-75 (1 gal.) 0 lb
 - 1) JOINT WRAP - 0.065"x6"x50' CONSEAL CS212 0 lb
 - 1) 48" - MH INVERT CHANNEL w/ConBlock-CDA Red - FULL HEIGHT 1440 lb
 - 2) CASTING - JBS 1155 F/C SANITARY 250 lb
 - 2) 48" - Conseal CS-102 1.00" (Double) 0 lb
 - 1) PSX - 12-08 NYLO 8 lb
 - 1) Quik-Lok - QL-08-C 1 lb
 - 7) MH Step ML-10-TDS-NCR - 10" 0 lb
- Structure Total: 8701 lb

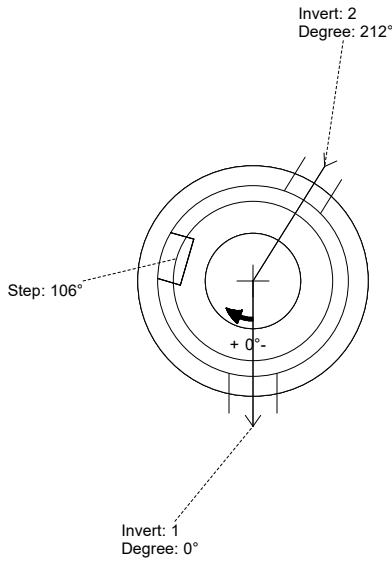

Position	Elev	Angle	Pipe	Pipe OD	Hole	Connector	Up (L)	Ref
Rim	601.21'							
Reducer								
Invert 1	593.4'	0°	8" PVC SDR26	8.5"	12"	PSX 12-08 NYLO	0"	P1
Invert 2	593.6'	212°	8" PVC SDR26	8.5"	10.75"	Quik-Lok QL-08-C	3.025"	P1
Invert 3								
Invert 4								
Invert 5								
Invert 6								
Invert 7								
Invert 8								

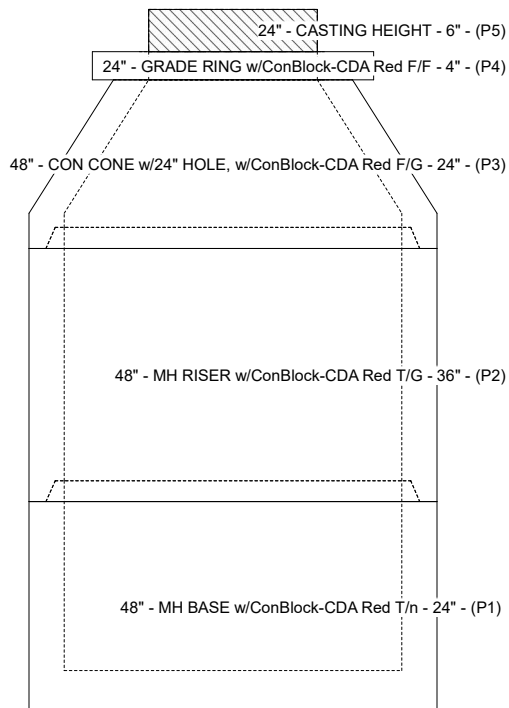

Cast (Int. Dim.) - Interior Dimensions

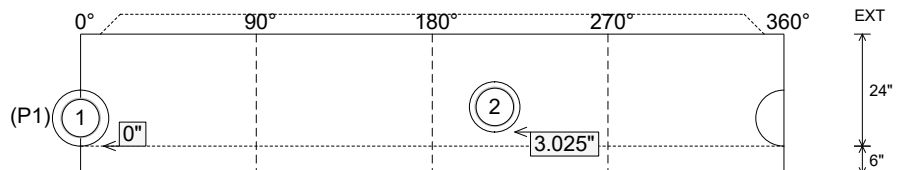

Submittal Drawing
 11/17/2025 2:03:32 PM

SUBMITTAL
 APPROVED BY: