

Job Name: 25-1145 - 7959 Poplar Creek
 Job Location: Nashville, TN 37221
 Contractor: Elite Constructors, Inc.

Plant: Beaver Dam, KY
 11/17/2025 11:33:59 AM

Tech: K. Cardwell
 PC: A. Chambers



Structure ID: MH-A2

P3 MH048CCN24CDARED

CON CONE w/24" HOLE, w/ConBlock-CDA Red F/G

- P4) 24" - CASTING HEIGHT - 6"
- P3) 48" - CON CONE w/24" HOLE, w/ConBlock-CDA Red F/G - 24"
- P2) 48" - MH RISER w/ConBlock-CDA Red T/G - 24"
- P1) 48" - MH BASE w/ConBlock-CDA Red T/n - 30"
- 1) JOINT WRAP PRIMER - CONSEAL CS-75 (1 gal.)
- 1) JOINT WRAP - 0.065"x6"x50' CONSEAL CS212
- 1) 48" - MH INVERT CHANNEL w/ConBlock-CDA Red - FULL HEIGHT
- 1) CASTING - JBS 1155 F/C SANITARY
- 2) 48" - Conseal CS-102 1.00" (Double)
- 2) PSX - 12-08 NYLO
- 6) MH Step ML-10-TDS-NCR - 10"

0 lb
 1297 lb
 1677 lb
 3330 lb
 0 lb
 0 lb
 1440 lb
 250 lb
 0 lb
 16 lb
 0 lb

Structure Total: 8010 lb

Structure Notes:
 STATION: 13+85.13
 1. PER ASTM C-478 SPECS
 2. CONCRETE: 4,500 PSI AT 28 DAYS
 3. REINFORCEMENT: PER ASTM A615
 4. CONBLOCK CDA RED ADMIXTURE REQUIRED
 5. INVERT CHANNEL REQUIRED
 6. STEPS AT 125 DEGREES
 7. JBS 1155 FRAME & COVER "SANITARY" SUPPLIED BY ICAST

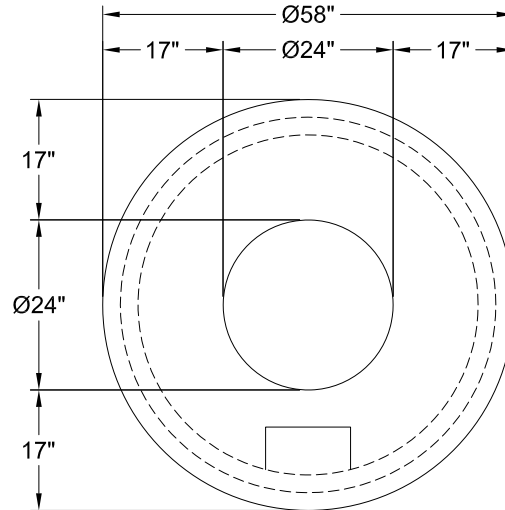

48" - CON CONE w/24" HOLE, w/ConBlock-CDA Red F/G - 24" - (P3)

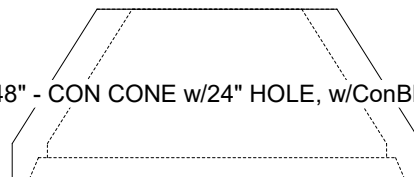

Coating (Int):
 Coating (Ext):

Seam Up: Flat
 Seam Dn: Groove

Wall Thickness: 5"

Height (Ext): 24"

Weight (Net): 1297 lb
 Volume (Net): 0.33cu.yd