

Job Name: 25-1145 - 7959 Poplar Creek
 Job Location: Nashville, TN 37221
 Contractor: Elite Constructors, Inc.

Plant: Beaver Dam, KY
 11/17/2025 11:33:02 AM

Tech: K. Cardwell
 PC: A. Chambers



Structure ID: MH-A2

P1 MH048BA30CDARED

MH BASE w/ConBlock-CDA Red T/n

- P4) 24" - CASTING HEIGHT - 6" 0 lb
 - P3) 48" - CON CONE w/24" HOLE, w/ConBlock-CDA Red F/G - 24" 1297 lb
 - P2) 48" - MH RISER w/ConBlock-CDA Red T/G - 24" 1677 lb
 - P1) 48" - MH BASE w/ConBlock-CDA Red T/n - 30" 3330 lb
 - 1) JOINT WRAP PRIMER - CONSEAL CS-75 (1 gal.) 0 lb
 - 1) JOINT WRAP - 0.065"x6"x50' CONSEAL CS212 0 lb
 - 1) 48" - MH INVERT CHANNEL w/ConBlock-CDA Red - FULL HEIGHT 1440 lb
 - 1) CASTING - JBS 1155 F/C SANITARY 250 lb
 - 2) 48" - Conseal CS-102 1.00" (Double) 0 lb
 - 2) PSX - 12-08 NYLO 16 lb
 - 6) MH Step ML-10-TDS-NCR - 10" 0 lb
- Structure Total: 8010 lb

Structure Notes:
 STATION: 13+85.13
 1. PER ASTM C-478 SPECS
 2. CONCRETE: 4,500 PSI AT 28 DAYS
 3. REINFORCEMENT: PER ASTM A615
 4. CONBLOCK CDA RED ADMIXTURE REQUIRED
 5. INVERT CHANNEL REQUIRED
 6. STEPS AT 125 DEGREES
 7. JBS 1155 FRAME & COVER "SANITARY" SUPPLIED BY ICAST

Rim: 586.89' Rim to Invert: 7.03' Slack: 2.36" Sump: 2" Step Position: 125

Position	Elev	Angle	Ext. (cw)	Pipe	Pipe OD	Connector	Hole	Horz Size	Up ()	Offset
Invert 1	579.86'	0°	0"	8" PVC SDR26	8.5"	PSX 12-08 NYLO	12"	12.129"	0"	0"
Invert 2	580.06'	251°	127.043"	8" PVC SDR26	8.5"	PSX 12-08 NYLO	12"	12.129"	2.4"	0"
Invert 3										
Invert 4										
Invert 5										
Invert 6										
Invert 7										
Invert 8										

RIGHT-SIDE UP VIEW (int. dimensions)

UPSIDE-DOWN VIEW (int. dimensions)

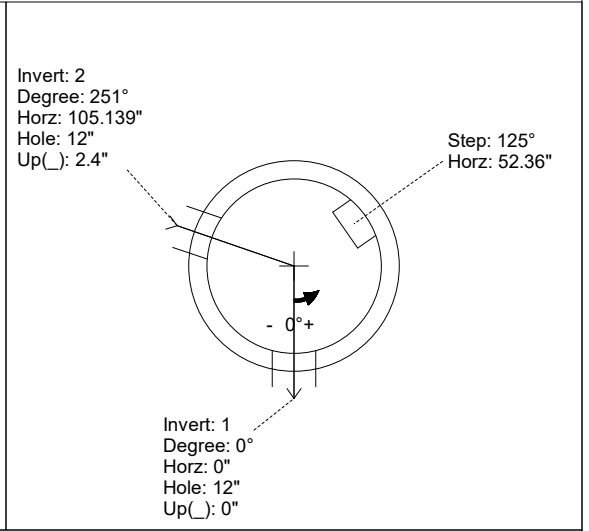
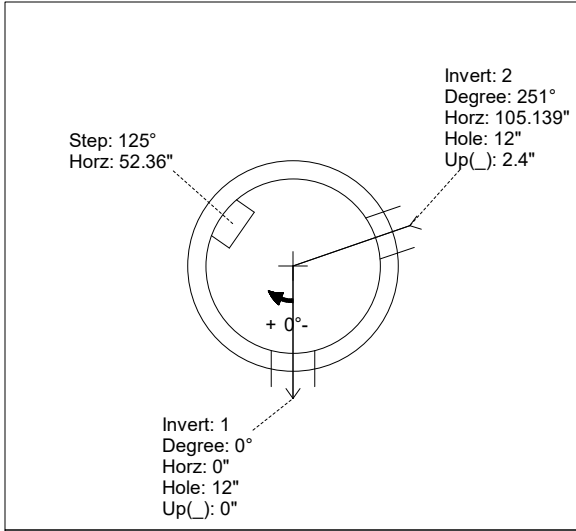
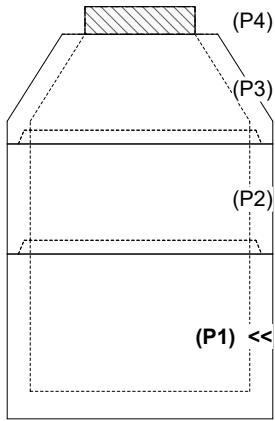

INSIDE WALL DIMENSIONS

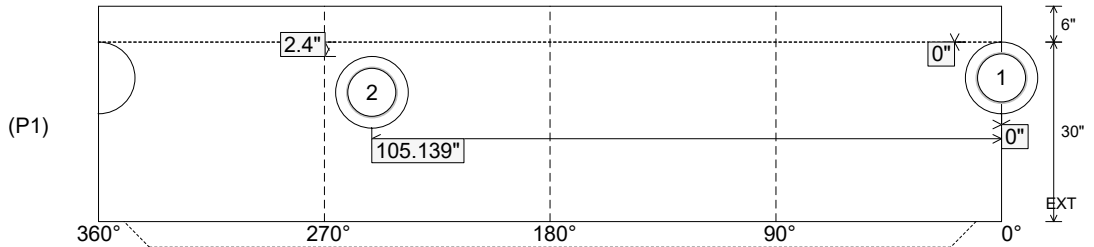

Coating (Int): Coating (Ext):	Seam Up: Tongue Seam Dn: n/a	Wall Thickness: 5" Floor Height: 6"	Height (Int): 30" Height (Ext): 36"	Weight (Net): 3330 lb Volume (Net): 0.85cu.yd
----------------------------------	---------------------------------	--	--	--

Job Name: 25-1145 - 7959 Poplar Creek
 Job Location: Nashville, TN 37221
 Contractor: Elite Constructors, Inc.

Plant: Beaver Dam, KY
 11/17/2025 11:33:02 AM

Tech: K. Cardwell
 PC: A. Chambers



Structure ID: MH-A2

P1 MH048BA30CDARED

MH BASE w/ConBlock-CDA Red T/n

P4) 24" - CASTING HEIGHT - 6"	0 lb
P3) 48" - CON CONE w/24" HOLE, w/ConBlock-CDA Red F/G - 24"	1297 lb
P2) 48" - MH RISER w/ConBlock-CDA Red T/G - 24"	1677 lb
P1) 48" - MH BASE w/ConBlock-CDA Red T/n - 30"	3330 lb
1) JOINT WRAP PRIMER - CONSEAL CS-75 (1 gal.)	0 lb
1) JOINT WRAP - 0.065"x6"x50' CONSEAL CS212	0 lb
1) 48" - MH INVERT CHANNEL w/ConBlock-CDA Red - FULL HEIGHT	1440 lb
1) CASTING - JBS 1155 F/C SANITARY	250 lb
2) 48" - Conseal CS-102 1.00" (Double)	0 lb
2) PSX - 12-08 NYLO	16 lb
6) MH Step ML-10-TDS-NCR - 10"	0 lb
Structure Total:	8010 lb

Structure Notes:
 STATION: 13+85.13
 1. PER ASTM C-478 SPECS
 2. CONCRETE: 4,500 PSI AT 28 DAYS
 3. REINFORCEMENT: PER ASTM A615
 4. CONBLOCK CDA RED ADMIXTURE REQUIRED
 5. INVERT CHANNEL REQUIRED
 6. STEPS AT 125 DEGREES
 7. JBS 1155 FRAME & COVER "SANITARY" SUPPLIED BY ICAST

Rim: 586.89' Rim to Invert: 7.03' Slack: 2.36" Sump: 2" Step Position: 125

Position	Elev	Angle	Ext. (cw)	Pipe	Pipe OD	Connector	Hole	Horz Size	Up ()	Offset
Invert 1	579.86'	0°	0"	8" PVC SDR26	8.5"	PSX 12-08 NYLO	12"	12.129"	0"	0"
Invert 2	580.06'	251°	127.043"	8" PVC SDR26	8.5"	PSX 12-08 NYLO	12"	12.129"	2.4"	0"
Invert 3										
Invert 4										
Invert 5										
Invert 6										
Invert 7										
Invert 8										

RIGHT-SIDE UP VIEW (int. dimensions)

UPSIDE-DOWN VIEW (int. dimenions)

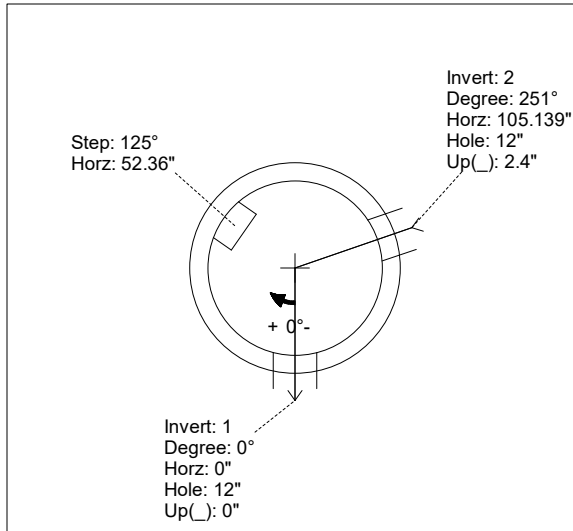
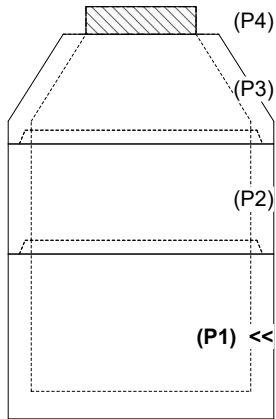

INVERT CHANNEL DRAWING

INSIDE WALL DIMENSIONS

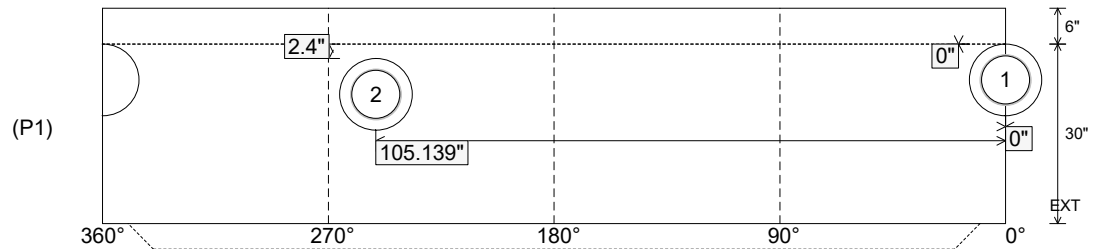

Coating (Int):
 Coating (Ext):

Seam Up: Tongue
 Seam Dn: n/a

Wall Thickness: 5"
 Floor Height: 6"

Height (Int): 30"
 Height (Ext): 36"

Weight (Net): 3330 lb
 Volume (Net): 0.85cu.yd