

**Job Name: 25-1145 - 7959 Poplar Creek**  
**Job Location: Nashville, TN 37221**  
**Contractor: Elite Constructors, Inc.**

PC: A. Chambers  
 TECH: K. Cardwell  
 Plant: Beaver Dam, KY



Structure ID: **A2.2**

Spec: Storm  
 Type: BX 6inW, 6inF  
 Size: 28" x 64"

Rim: 600.62'  
 Invert: 596'  
 Rim to Invert: 4.62'

Sump: 0"  
 Floor (Top): 596'  
 Floor Height: 6"

Floor (Bot): 595.5'  
 Overall Height: 5.083'  
 Slack: 0.44"

**Structure Notes:**

- STATION: 10+67.99  
 1. PER ASTM C-913 SPECS  
 2. CONCRETE: 4,500 PSI AT 28 DAYS  
 3. REINFORCEMENT: #4 BAR @ 12" C.C. E.W. (GRADE 60)  
 4. 2 EA. JBS 3101-V FRAMES, L-VANE GRATES, & CURB HOODS SUPPLIED BY ICAST  
 5. LINTEL BAR SLOTS CENTERED IN EACH LONG WALL REQUIRED (7" LONG X 1" DEEP X FULL WIDTH OF WALL)

**STRUCTURE SUMMARY:**

- P2) 28" x 64" - CASTING HEIGHT - 6" 0 lb  
 P1) 28" x 64" - BOX BASE 6inW, 6inF, Variable Ht F/n - 49" 6388 lb  
 1) CASTING - JBS 3101V Double Set (F/G/H) 1238 lb  
 1) 28" x 64" - Conseal CS-102 1.00" 0 lb  
 1) Hole - 26 0 lb  
 2) LINTEL BAR SLOT n/n - 7"x1" 0 lb  
 Structure Total: 7626 lb

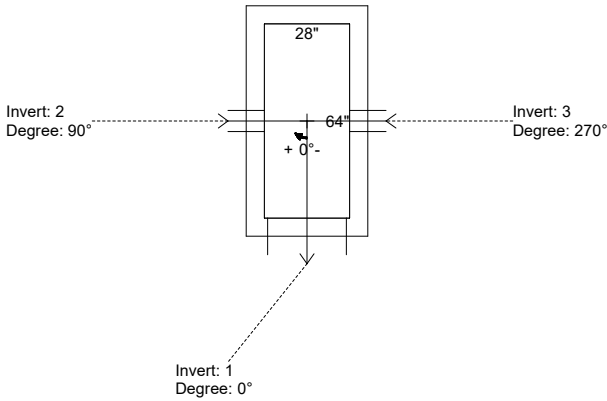

Position	Elev	Angle	Pipe	Pipe OD	Hole	Connector	Up (L)	Ref
Rim	600.62'							
Reducer								
Invert 1	596'	0°	18" RCP B WALL	23"	26"	Hole 26	-2.5"	P1
Invert 2	600'	90°	7" x 1" LINTEL BAR SLOT	7" x 1"	7" x 1"	LINTEL BAR SLOT 7"x1"	48"	P1
Invert 3	600'	270°	7" x 1" LINTEL BAR SLOT	7" x 1"	7" x 1"	LINTEL BAR SLOT 7"x1"	48"	P1
Invert 4								
Invert 5								
Invert 6								
Invert 7								
Invert 8								

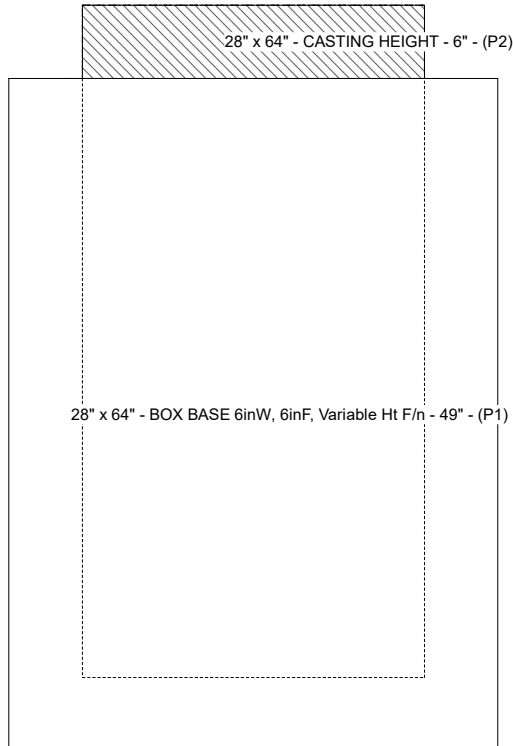

**Cast (Int. Dim.) - Interior Dimensions**

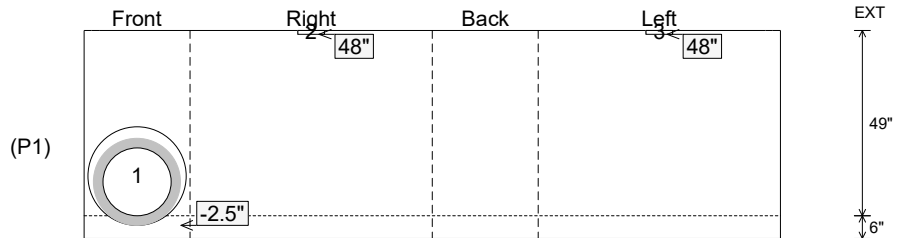

Submittal Drawing  
 11/17/2025 2:03:15 PM

SUBMITTAL  
 APPROVED BY: