

Job Name: 25-1145 - 7959 Poplar Creek
 Job Location: Nashville, TN 37221
 Contractor: Elite Constructors, Inc.

Plant: Beaver Dam, KY
 11/17/2025 11:33:39 AM

Tech: K. Cardwell
 PC: A. Chambers



Structure ID: A2

P2 BX2864-06R24

BOX RISER 6inW F/G

- P3) 28" x 64" - CASTING HEIGHT - 6"
- P2) 28" x 64" - BOX RISER 6inW F/G - 24"
- P1) 28" x 64" - BOX BASE 6inW, 6inF, Variable Ht T/n - 37"
- 1) CASTING - JBS 3101V Double Set (F/G/H)
- 2) 28" x 64" - Conseal CS-102 1.00"
- 4) Hole - 26
- 2) LINTEL BAR SLOT n/n - 7"x1"

0 lb
 2506 lb
 4317 lb
 1238 lb
 0 lb
 0 lb
 0 lb

 Structure Total: 8061 lb

- Structure Notes:**
 STATION: 12+20.75
1. PER ASTM C-913 SPECS
 2. CONCRETE: 4,500 PSI AT 28 DAYS
 3. REINFORCEMENT: #4 BAR @ 12" C.C. E.W. (GRADE 60) - 2" MIN. REBAR CLEARANCE (TYP)
 4. 2 EA. JBS 3101-V FRAMES, L-VANE GRATES, & CURB HOODS SUPPLIED BY ICAST
 5. LINTEL BAR SLOTS CENTERED IN EACH LONG WALL REQUIRED (7" LONG X 1" DEEP X FULL WIDTH OF WALL)

Rim: 599.59' Rim to Invert: 5.59' Slack: 0.08" Sump: 0" Step Position:

Position	Elev	Angle	Ext. (cw)	Pipe	Pipe OD	Connector	Hole	Horz Size	Up ()	Offset
Invert 1										
Invert 2										
Invert 3										
Invert 4										
Invert 5	599'	90°	38"	7" x 1" LINTEL BAR SLOT	7" x 1"	LINTEL BAR SLOT 7"x1"	7" x 1"	7"	21"	0"
Invert 6	599'	270°	38"	7" x 1" LINTEL BAR SLOT	7" x 1"	LINTEL BAR SLOT 7"x1"	7" x 1"	7"	21"	0"
Invert 7										
Invert 8										

RIGHT-SIDE UP VIEW (int. dimensions)

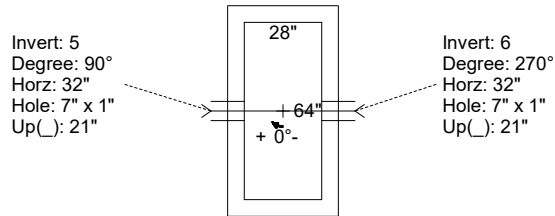
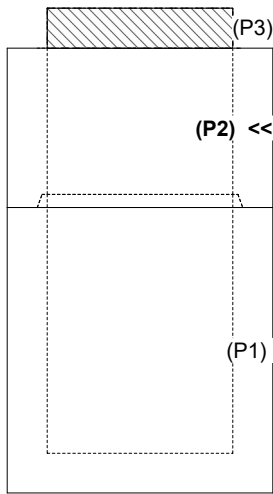

INSIDE WALL DIMENSIONS

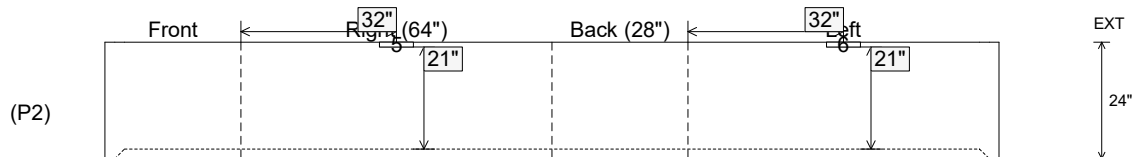

Coating (Int):
 Coating (Ext):

Seam Up: Flat
 Seam Dn: Groove

Wall Thickness: 6"
 Floor Height: 0"

Height (Int): 24"
 Height (Ext): 24"

Weight (Net): 2506 lb
 Volume (Net): 0.64cu.yd

GENERAL NOTES:

- RECESSES FOR LINTEL BARS TO BE 7" LONG X 1" DEEP X FULL WIDTH OF WALL.

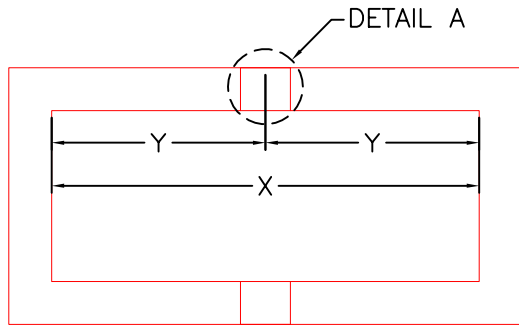

PLAN VIEW
DOUBLE INLET

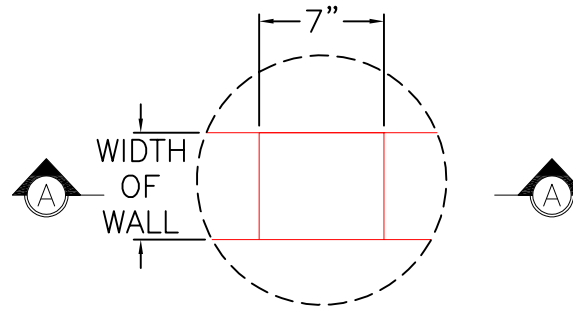

DETAIL A

X	Y
54"	27"
56"	28"
60"	30"
64"	32"
72"	36"

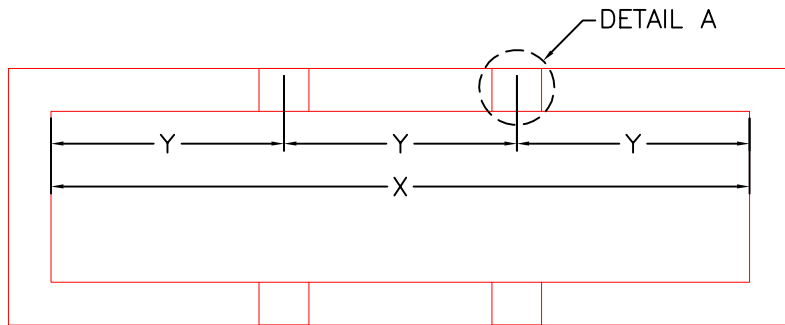

PLAN VIEW
TRIPLE INLET

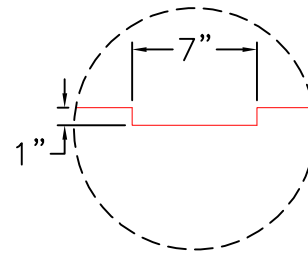

SECTION A-A

X	Y
96"	32"
98"	32 ³ / ₄ "
108"	36"

PRODUCTION WORK ORDER

PRODUCT I.D.: -

DESCRIPTION: LINTEL BAR POCKET LOCATIONS



QUALITY CONTROL CHECKLIST

- ALL DIMENSIONS CORRECT.
- LIFTERS INSTALLED.
- OPENING CENTERED.
- REINFORCING CORRECT.
- SURFACE QUALITY ACCEPTABLE.
- EDGES CHAMFERED.
- ALL PATCHWORK ACCEPTABLE.

PRODUCT VIEW: RIGHT SIDE UP

CUSTOMER: N/A

PLANT: BEAVER DAM, KY.

PROJECT: N/A

WEIGHT: N/A.

STRUCTURE: N/A

TOP SECTION JOINT: N/A

ORDER NO: N/A

BASE SECTION JOINT: N/A

PE: J.H. ROSS

DRAWING: J. COPPAGE

QC CHECK INITIALS:

DATE: 3/6/24

SCALE: NTS

PG. 1 of 1