

Job Name: 25-1137B - East Bank Regional Pump Station
 Job Location: Nashville, TN
 Contractor: Garney Companies, Inc.

Plant: Beaver Dam

Tech: J. Coppage

12/12/2025 10:08:45 AM

PC: J. Jarvis



Structure ID: Valve Vault

P2 CVR-X

BOX RISER 8inW, Variable Ht w/Xypex FB

- P5) 42" x 42" - HATCH (CAST FLUSH) - 3"
- P4) 108" x 156" - BX FLAT LID 8inW w/ XYPEX AND 3 HATCHES - 8"
- P3) 108" x 156" - BOX RISER 8inW, Variable Ht w/Xypex FT - 37"
- P2) 108" x 156" - BOX RISER 8inW, Variable Ht w/Xypex FB - 60"
- P1) 108" x 156" - P.I.P. BY OTHERS - BTM SLAB - 0"
- 4) DOGHOUSE - 22"x22"

Structure Total: 45420 lb

Structure Notes:

1. MANUFACTURED TO ASTM C-913 (LATEST REVISION).
2. CONCRETE: 4,500 PSI AT 28 DAYS.
3. XYPEX ADMIXTURE REQUIRED.
4. REINFORCING: PER ASTM A615 (GRADE 60).
5. TWO HALLIDAY F1H 42" X 42" HATCHES AND ONE HALLIDAY F1H 36" X 36" HATCH PROVIDED BY ICAST.
6. ALL HATCHES TO HAVE FALL PROTECTION.
7. TOP SLAB TO HAVE MINIMUM 1/4" CROWNED SLOPE PER FOOT AND A BRUSH FINISH.
8. HATCHES TO BE CAST IN TOP SLAB.

Rim: 417.25' Rim to Invert: 7' Slack: 0" Sump: 21" Step Position:

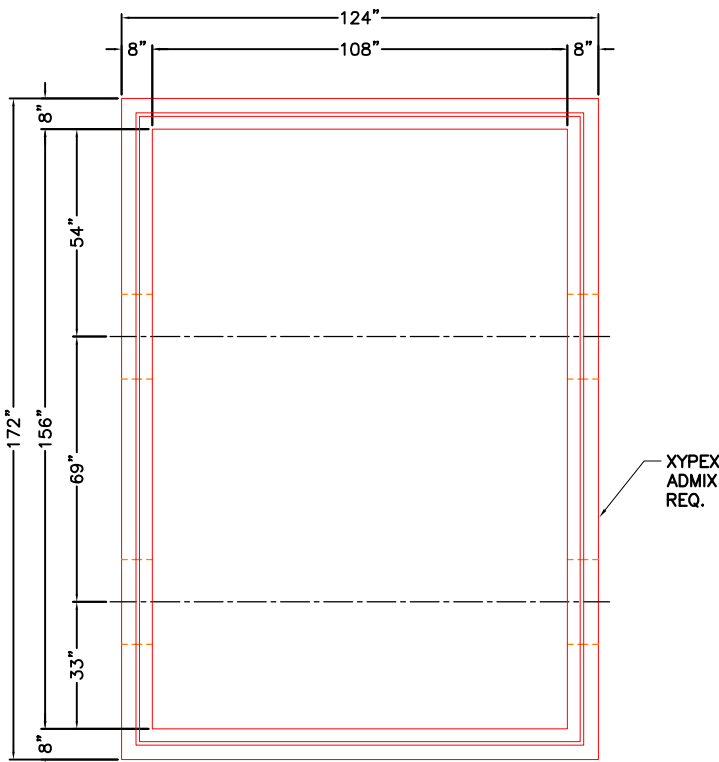

TOP VIEW

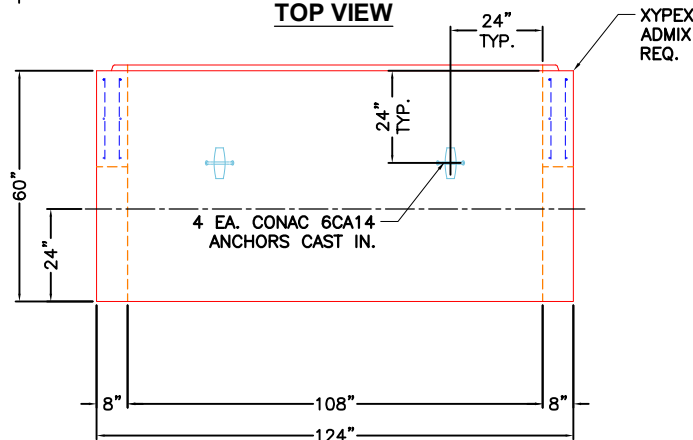

FRONT VIEW

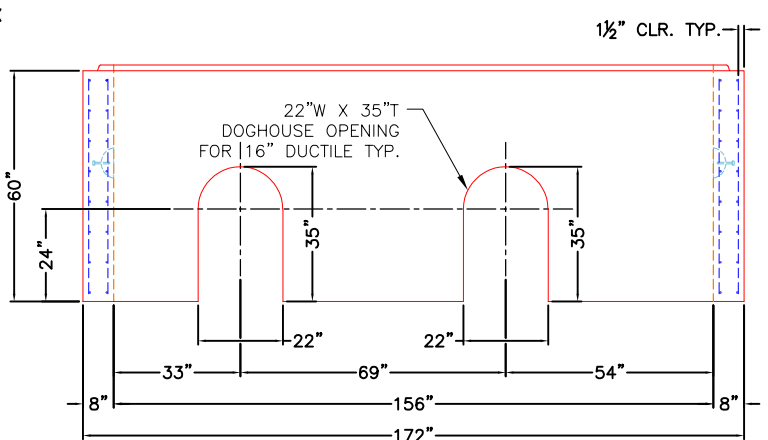

RIGHT VIEW

GENERAL NOTES:

1. MANUFACTURED TO ASTM C-913 (LATEST REVISION).
2. CONCRETE: 4,500 PSI AT 28 DAYS.
3. XYPEX ADMIXTURE REQUIRED.
4. REINFORCING: PER ASTM A615 (GRADE 60).
 HORIZONTALS - #5 BAR @ 6" O.C.
 OUTER VERTICALS - #5 BAR @ 6" O.C.
 INNER VERTICALS - #5 BAR @ 12" O.C.
5. WEIGHT: 20,332 LBS.

Coating (Int):
 Coating (Ext):

Seam Up: Tongue
 Seam Dn: Flat

Wall Thickness: 8"
 Floor Height: 0"

Height (Int): 60"
 Height (Ext): 60"

Weight (Net): 20332 lb
 Volume (Net): 5.19cu.yd