

Job Name: 25-1137B - East Bank Regional Pump Station  
 Job Location: Nashville, TN  
 Contractor: Garney Companies, Inc.

Plant: Beaver Dam

Tech: J. Coppage

11/5/2025 12:06:22 PM

PC: J. Jarvis



**Structure ID: MH-200 1+04**

**P1 MH072BA72X**

**MH BASE w/XYPEX**

P7) 24" - CASTING HEIGHT - 7"	0 lb
P6) 24" - XYPEX GRADE RING - 3"	202 lb
P5) 48" - CON XYPEX CONE w/24" HOLE - 36"	2251 lb
P4) 48" - MH RISER w/XYPEX - 48"	3353 lb
P3) 48" - MH RISER w/XYPEX - 48"	3353 lb
P2) 72" - XYPEX MH FT REDUCER 48" HOLE - 15"	3864 lb
P1) 72" - MH BASE w/XYPEX - 72"	13620 lb
1) JOINT WRAP PRIMER - CONSEAL CS-75 (1 gal.)	0 lb
1) JOINT WRAP - 0.065"x6"x50' CONSEAL CS212	0 lb
1) 72" - SAN. INV. CHANNEL - FULL HEIGHT	5422 lb
1) 72" - DBL 1"x14.5' Butyl (2x)	0 lb
3) 48" - DBL 1"x14.5' Butyl (2x)	0 lb
1) A-Lok - 1240	1 lb
<b>Structure Total:</b>	<b>32068 lb</b>

**Structure Notes:**  
 1. JBS-1150 METRO SANITARY BY ICAST.  
 2. PER ASTM C478 SPECIFICATIONS.  
 3. CONCRETE = 4,500 PSI AT 28 DAYS.  
 4. REINFORCING PER ASTM A615 (GRADE 60)  
 - TOP (As .62) #5 BAR AT 6" C/C E.W.  
 - WALLS (As .18) WWF OR EQUIV.  
 - FLOOR (As .20) #4 BAR AT 12" C/C E.W. DOUBLE MAT

Rim: 416.68' Rim to Invert: 18.97' Slack: 0.64" Sump: 2" Step Position: 90°

Position	Elev	Angle	Ext. (cw)	Pipe	Pipe OD	Connector	Hole	Horz Size	Up ( )	Offset
Invert 1	397.71'	0°	0"	36" DI	38.5"	A-Lok 1240	40"	42.41"	0"	0"
Invert 2										
Invert 3										
Invert 4										
Invert 5										
Invert 6										
Invert 7										
Invert 8										

RIGHT-SIDE UP VIEW (int. dimensions)

UPSIDE-DOWN VIEW (int. dimensions)

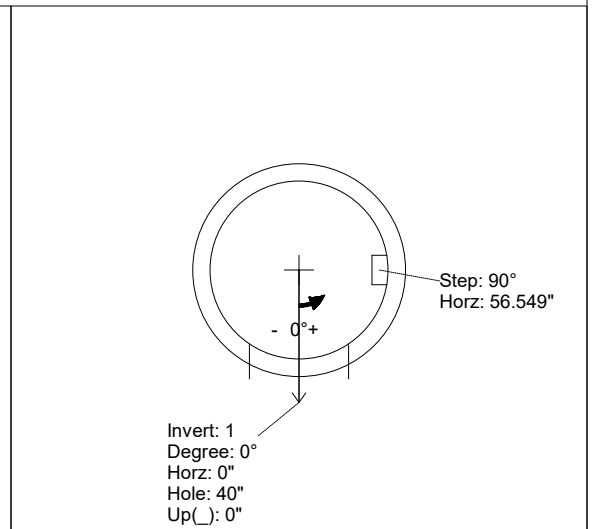
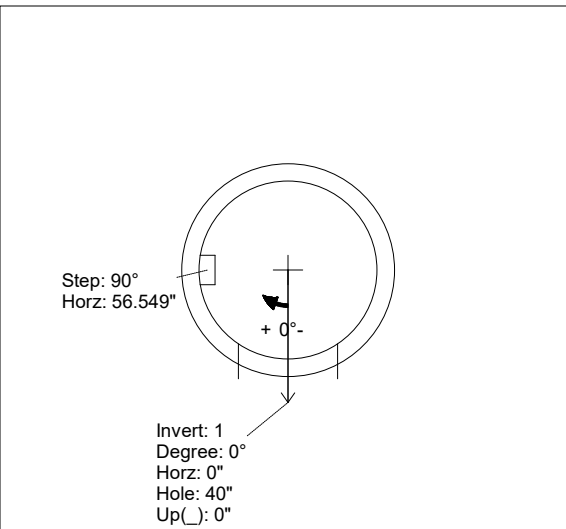
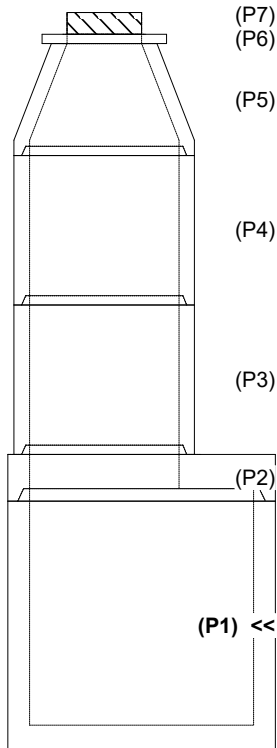

INSIDE WALL DIMENSIONS

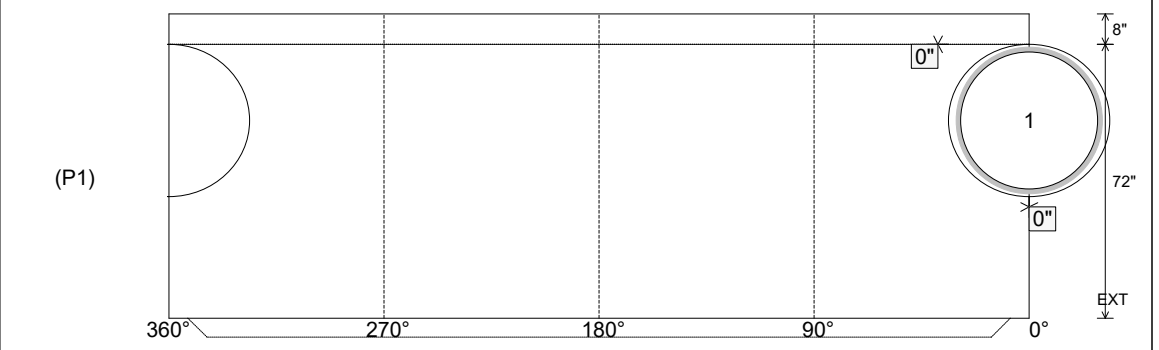

Coating (Int): Coating (Ext):	Seam Up: Tongue Seam Dn: n/a	Wall Thickness: 7" Floor Height: 8"	Height (Int): 72" Height (Ext): 80"	Weight (Net): 13620 lb Volume (Net): 3.48cu.yd
----------------------------------	---------------------------------	--	--	---

Job Name: 25-1137B - East Bank Regional Pump Station  
 Job Location: Nashville, TN  
 Contractor: Garney Companies, Inc.

Plant: Beaver Dam

Tech: J. Coppage

11/5/2025 12:06:22 PM

PC: J. Jarvis



**Structure ID: MH-200 1+04**

**P1 MH072BA72X**

**MH BASE w/XYPEX**

- P7) 24" - CASTING HEIGHT - 7"
- P6) 24" - XYPEX GRADE RING - 3"
- P5) 48" - CON XYPEX CONE w/24" HOLE - 36"
- P4) 48" - MH RISER w/XYPEX - 48"
- P3) 48" - MH RISER w/XYPEX - 48"
- P2) 72" - XYPEX MH FT REDUCER 48" HOLE - 15"
- P1) 72" - MH BASE w/XYPEX - 72"
- 1) JOINT WRAP PRIMER - CONSEAL CS-75 (1 gal.)
- 1) JOINT WRAP - 0.065"x6"x50' CONSEAL CS212
- 1) 72" - SAN. INV. CHANNEL - FULL HEIGHT
- 1) 72" - DBL 1"x14.5' Butyl (2x)
- 3) 48" - DBL 1"x14.5' Butyl (2x)
- 1) A-Lok - 1240

- |  |  |
|--|--|
| <ul style="list-style-type: none"> <li>0 lb</li> <li>202 lb</li> <li>2251 lb</li> <li>3353 lb</li> <li>3353 lb</li> <li>3864 lb</li> <li>13620 lb</li> <li>0 lb</li> <li>0 lb</li> <li>5422 lb</li> <li>0 lb</li> <li>0 lb</li> <li>1 lb</li> <li>-----</li> <li>32068 lb</li> </ul> | <p><b>Structure Notes:</b></p> <ol style="list-style-type: none"> <li>1. JBS-1150 METRO SANITARY BY ICAST.</li> <li>2. PER ASTM C478 SPECIFICATIONS.</li> <li>3. CONCRETE = 4,500 PSI AT 28 DAYS.</li> <li>4. REINFORCING PER ASTM A615 (GRADE 60)</li> </ol> <ul style="list-style-type: none"> <li>- TOP (As .62) #5 BAR AT 6" C/C E.W.</li> <li>- WALLS (As .18) WWF OR EQUIV.</li> <li>- FLOOR (As .20) #4 BAR AT 12" C/C E.W. DOUBLE MAT</li> </ul> |
|--|--|

INVERT CHANNEL DRAWING  
 FULL HEIGHT INVERT

Structure Total: 32068 lb

Rim: 416.68'    Rim to Invert: 18.97'    Slack: 0.64"    Sump: 2"    Step Position: 90°

Position	Elev	Angle	Ext. (cw)	Pipe	Pipe OD	Connector	Hole	Horz Size	Up ( )	Offset
Invert 1	397.71'	0°	0"	36" DI	38.5"	A-Lok 1240	40"	42.41"	0"	0"
Invert 2										
Invert 3										
Invert 4										
Invert 5										
Invert 6										
Invert 7										
Invert 8										

RIGHT-SIDE UP VIEW (int. dimensions)

UPSIDE-DOWN VIEW (int. dimensions)

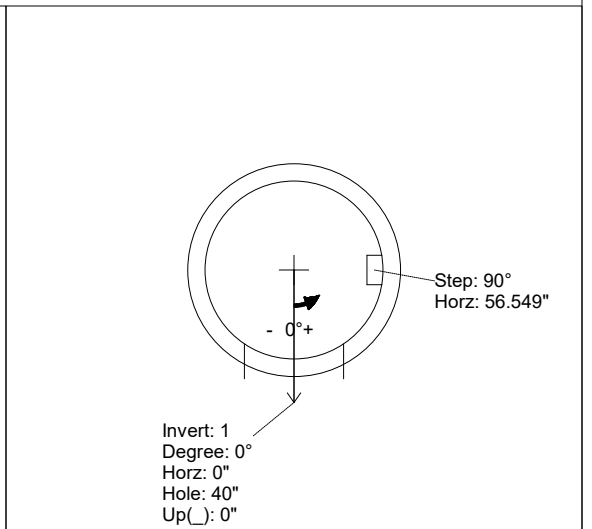
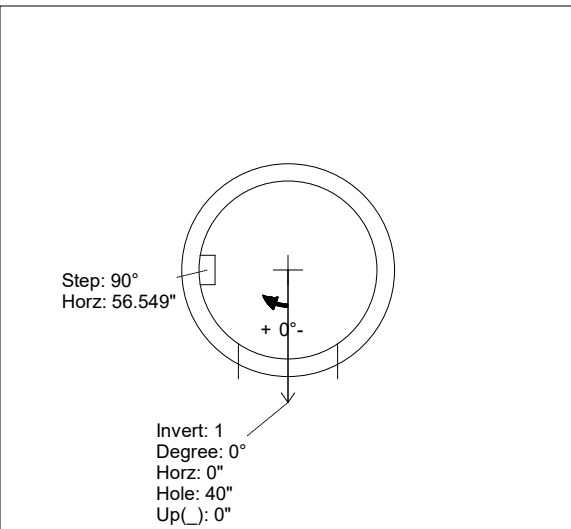
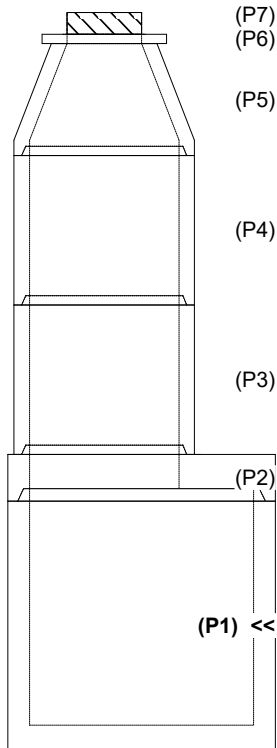

INSIDE WALL DIMENSIONS

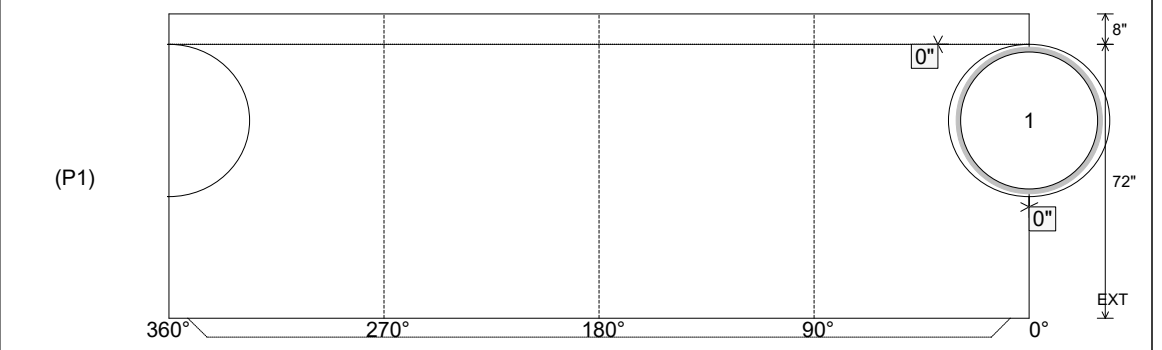

Coating (Int):  
 Coating (Ext):

Seam Up: Tongue  
 Seam Dn: n/a

Wall Thickness: 7"  
 Floor Height: 8"

Height (Int): 72"  
 Height (Ext): 80"

Weight (Net): 13620 lb  
 Volume (Net): 3.48cu.yd