

Job Name: 25-1137B - East Bank Regional Pump Station  
 Job Location: Nashville, TN  
 Contractor: Garney Companies, Inc.

Plant: Beaver Dam

Tech: J. Coppage

3/3/2026 11:45:52 AM

PC: J. Jarvis



**Structure ID: MH-006 10+57**

**P1 MH048BA42X**

**MH BASE w/XYPEX**

- P5) 24" - CASTING HEIGHT - 7"
- P4) 24" - XYPEX GRADE RING - 4"
- P3) 48" - CON XYPEX CONE w/24" HOLE - 36"
- P2) 48" - MH RISER w/XYPEX - 72"
- P1) 48" - MH BASE w/XYPEX - 42"
- 1) JOINT WRAP PRIMER - CONSEAL CS-75 (1 gal.)
- 1) JOINT WRAP - 0.065"x6"x50' CONSEAL CS212
- 1) 48" - SAN. INV. CHANNEL w/XYPEX - FULL HEIGHT
- 1) CASTING - JBS 1150 F/C SANITARY
- 2) 48" - Conseal CS-102 1.00" (Double)
- 2) Kor-N-Seal2 - S206-30

- Structure Notes:**
1. JBS-1150 METRO SANITARY BY ICAST.
  2. PER ASTM C478 SPECIFICATIONS.
  3. CONCRETE = 4,500 PSI AT 28 DAYS.
  4. REINFORCING PER ASTM A615 (GRADE 60)
- CONE (As .12)
  - RISER/WALLS (As .12)
  - FLOOR (As .31) #5 BARS AT 12" C.C.E.W.
- NOTE: KOR-N-SEAL BOOTS SUPPLIED BY OTHERS

Structure Total: 12886 lb

Rim: 419.62' Rim to Invert: 13.31' Slack: 1.72" Sump: 3" Step Position: 270°

Position	Elev	Angle	Ext. (cw)	Pipe	Pipe OD	Connector	Hole	Horz Size	Up ( )	Offset
Invert 1	406.31'	0°	0"	24" DI	25.75"	Kor-N-Seal2 S206-30	30"	32.406"	0"	0"
Invert 2	406.41'	180°	91.106"	24" DI	25.75"	Kor-N-Seal2 S206-30	30"	32.406"	1.2"	0"
Invert 3										
Invert 4										
Invert 5										
Invert 6										
Invert 7										
Invert 8										

RIGHT-SIDE UP VIEW (int. dimensions)

UPSIDE-DOWN VIEW (int. dimensions)

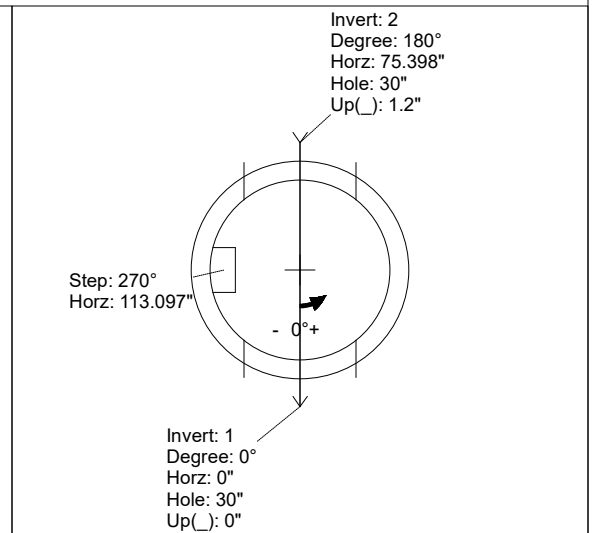
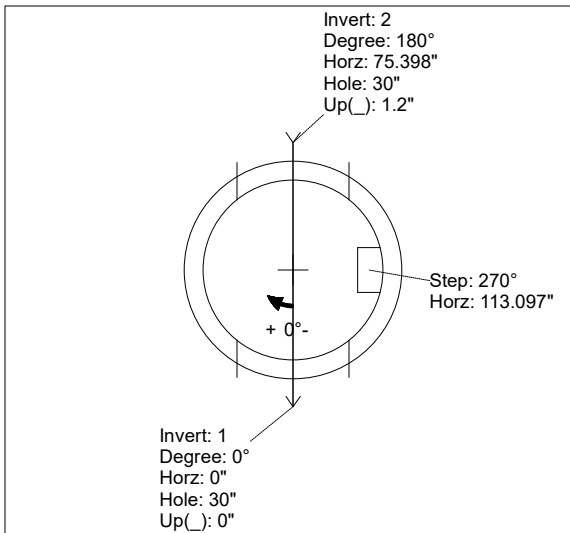
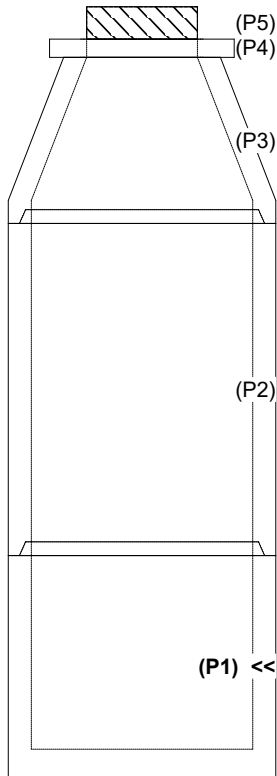

INSIDE WALL DIMENSIONS

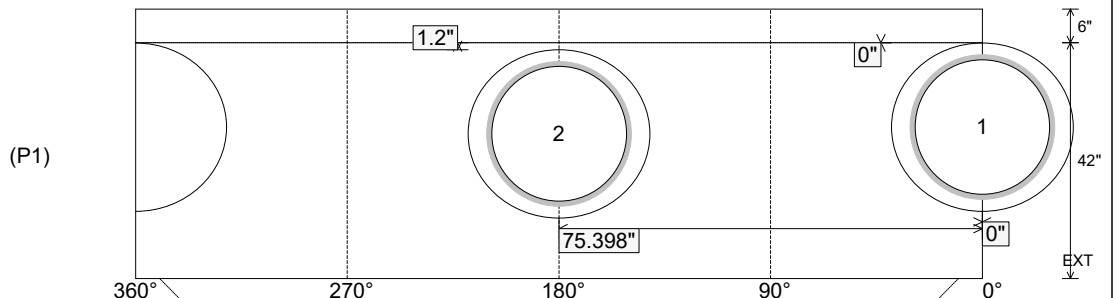

Coating (Int):  
 Coating (Ext):

Seam Up: Tongue  
 Seam Dn: n/a

Wall Thickness: 5"  
 Floor Height: 6"

Height (Int): 42"  
 Height (Ext): 48"

Weight (Net): 3632 lb  
 Volume (Net): 0.93cu.yd

Job Name: 25-1137B - East Bank Regional Pump Station  
 Job Location: Nashville, TN  
 Contractor: Garney Companies, Inc.

Plant: Beaver Dam

Tech: J. Coppage

3/3/2026 11:45:52 AM

PC: J. Jarvis



**Structure ID: MH-006 10+57**

**P1 MH048BA42X**

**MH BASE w/XYPEX**

- P5) 24" - CASTING HEIGHT - 7"
- P4) 24" - XYPEX GRADE RING - 4"
- P3) 48" - CON XYPEX CONE w/24" HOLE - 36"
- P2) 48" - MH RISER w/XYPEX - 72"
- P1) 48" - MH BASE w/XYPEX - 42"
- 1) JOINT WRAP PRIMER - CONSEAL CS-75 (1 gal.)
- 1) JOINT WRAP - 0.065"x6"x50' CONSEAL CS212
- 1) 48" - SAN. INV. CHANNEL w/XYPEX - FULL HEIGHT
- 1) CASTING - JBS 1150 F/C SANITARY
- 2) 48" - Conseal CS-102 1.00" (Double)
- 2) Kor-N-Seal2 - S206-30

- Structure Notes:**
1. JBS-1150 METRO SANITARY BY ICAST.
  2. PER ASTM C478 SPECIFICATIONS.
  3. CONCRETE = 4,500 PSI AT 28 DAYS.
  4. REINFORCING PER ASTM A615 (GRADE 60)
    - CONE (As .12)
    - RISER/WALLS (As .12)
    - FLOOR (As .31) #5 BARS AT 12" C.C.E.W.
- NOTE: KOR-N-SEAL BOOTS SUPPLIED BY OTHERS

Structure Total: 12886 lb

**INVERT CHANNEL DRAWING  
FULL HEIGHT INVERT**

Rim: 419.62' Rim to Invert: 13.31' Slack: 1.72" Sump: 3" Step Position: 270°

Position	Elev	Angle	Ext. (cw)	Pipe	Pipe OD	Connector	Hole	Horz Size	Up ( )	Offset
Invert 1	406.31'	0°	0"	24" DI	25.75"	Kor-N-Seal2 S206-30	30"	32.406"	0"	0"
Invert 2	406.41'	180°	91.106"	24" DI	25.75"	Kor-N-Seal2 S206-30	30"	32.406"	1.2"	0"
Invert 3										
Invert 4										
Invert 5										
Invert 6										
Invert 7										
Invert 8										

RIGHT-SIDE UP VIEW (int. dimensions)

UPSIDE-DOWN VIEW (int. dimensions)

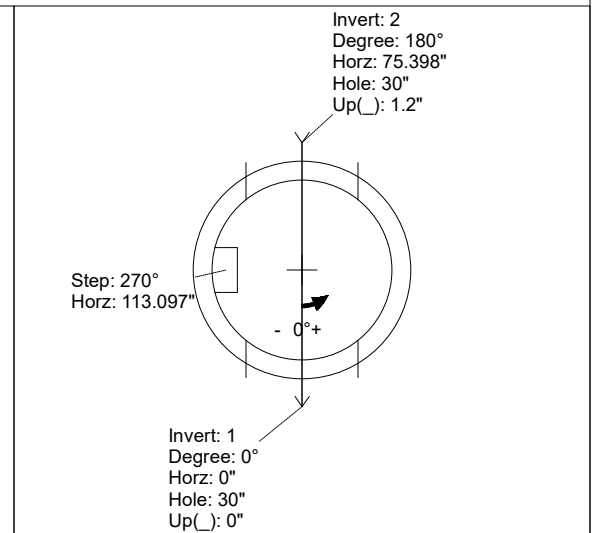
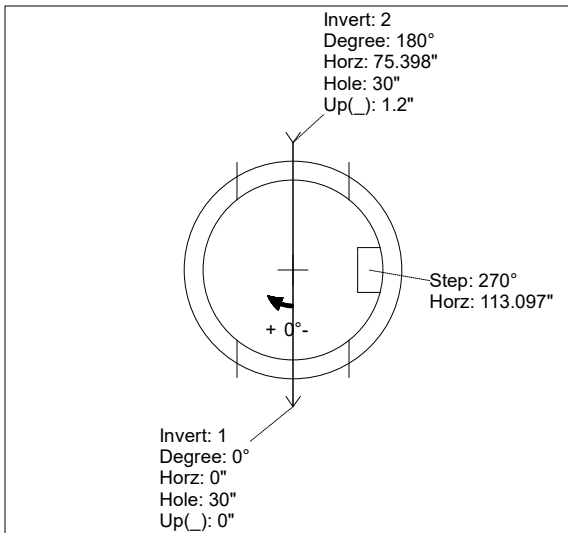
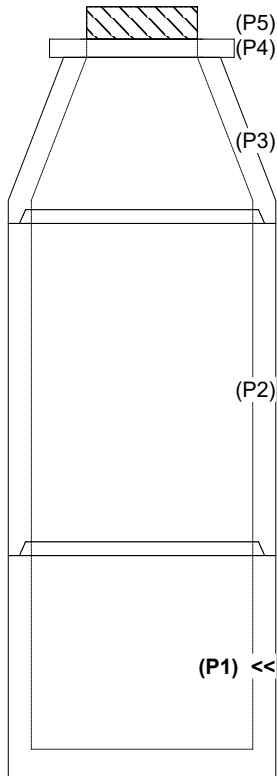

INSIDE WALL DIMENSIONS

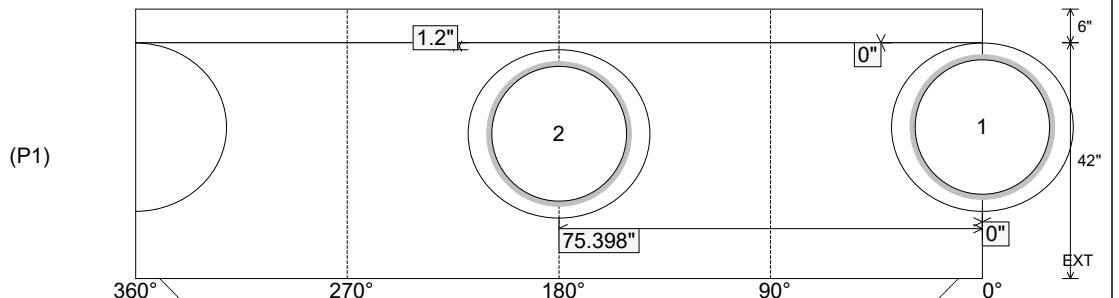

Coating (Int):  
Coating (Ext):

Seam Up: Tongue  
Seam Dn: n/a

Wall Thickness: 5"  
Floor Height: 6"

Height (Int): 42"  
Height (Ext): 48"

Weight (Net): 3632 lb  
Volume (Net): 0.93cu.yd