

Job Name: 25-1137B - East Bank Regional Pump Station
 Job Location: Nashville, TN
 Contractor: Garney Companies, Inc.

Plant: Beaver Dam

Tech: J. Coppage

3/3/2026 11:46:47 AM

PC: J. Jarvis



Structure ID: MH-004 6+34

P2 MH096RS96X

MH RISER w/YYPEX

- P8) 24" - CASTING HEIGHT - 7"
- P7) 24" - XYPEX GRADE RING - 6"
- P6) 48" - CON XYPEX CONE w/24" HOLE - 36"
- P5) 48" - MH RISER w/XYPEX - 36"
- P4) 48" - MH RISER w/XYPEX - 72"
- P3) 96" - MH Transition Slab 48" Hole w/ Xypex - 17"
- P2) 96" - MH RISER w/XYPEX - 96"
- P1) 96" - MH BASE SLAB w/XYPEX - 8"
- 1) JOINT WRAP PRIMER - CONSEAL CS-75 (1 gal.)
- 1) JOINT WRAP - 0.065"x6"x50' CONSEAL CS212
- 1) CASTING - JBS 1150 F/C SANITARY
- 2) 96" - Conseal CS-102 1.00" (Double)
- 3) 48" - Conseal CS-102 1.00" (Double)
- 1) Kor-N-Seal2 - S206-54L
- 1) Kor-N-Seal2 - S206-30

- Structure Notes:**
1. JBS-1150 METRO SANITARY BY ICAST.
 2. PER ASTM C478 SPECIFICATIONS.
 3. CONCRETE = 4,500 PSI AT 28 DAYS.
 4. REINFORCING PER ASTM A615 (GRADE 60)
 - TOP (As .62) #5 BAR AT 6" C/C E.W.
 - WALLS (As .18) WWF OR EQUIV.
 - FLOOR (As .20) #4 BAR AT 12" C/C E.W. DOUBLE MAT
- NOTE: KOR-N-SEAL BOOTS SUPPLIED BY OTHERS

0 lb
 405 lb
 2251 lb
 2515 lb
 5030 lb
 9106 lb
 21554 lb
 10880 lb
 0 lb
 0 lb
 250 lb
 0 lb
 0 lb
 0 lb
 6 lb
 6 lb

Rim: 419.43' Rim to Invert: 21.46' Slack: 1.56' Sump: 14.04" Structure Step Position: 225"

Position	Elev	Angle	Ext. (cw)	Pipe	Pipe OD	Connector	Hole	Horz Size	Up ()	Offset
Invert 1	397.97'	0°	0"	48" DI	50.75"	Kor-N-Seal2 S206-54L	54"	57.351"	6.04"	0"
Invert 2	399.97'	90°	89.535"	24" DI	25.75"	Kor-N-Seal2 S206-30	30"	30.511"	30.04"	0"
Invert 3										
Invert 4										
Invert 5										
Invert 6										
Invert 7										
Invert 8										

RIGHT-SIDE UP VIEW (int. dimensions)

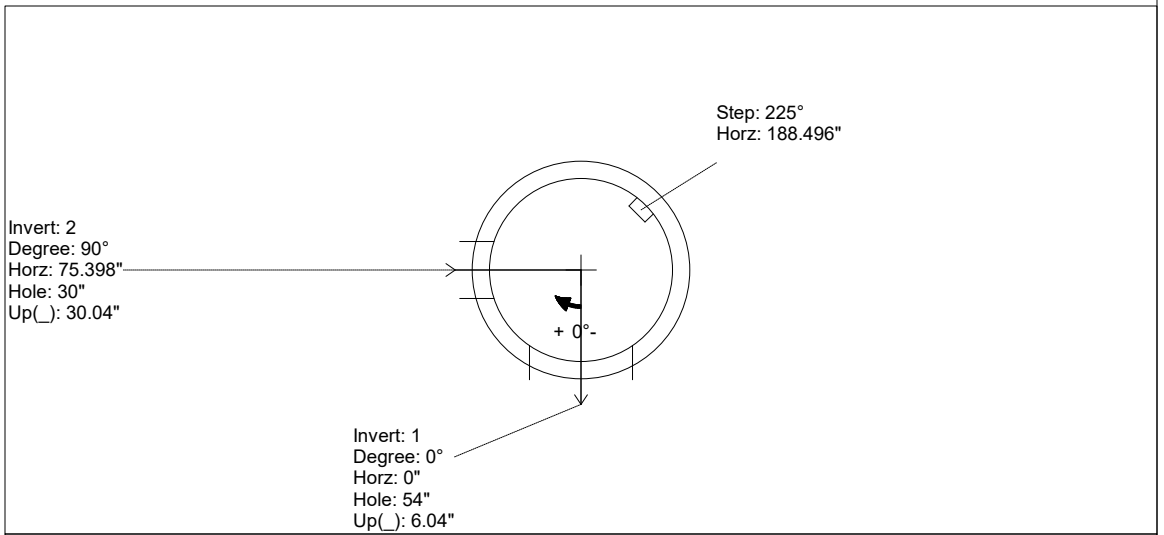
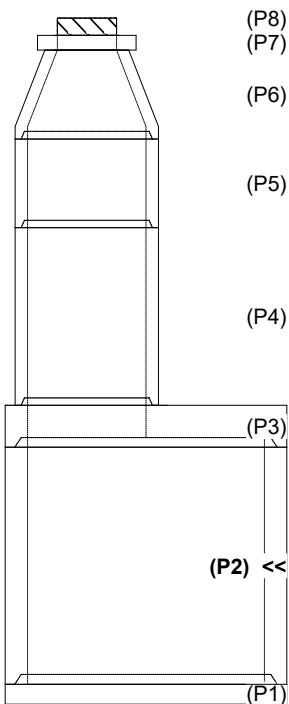

INSIDE WALL DIMENSIONS

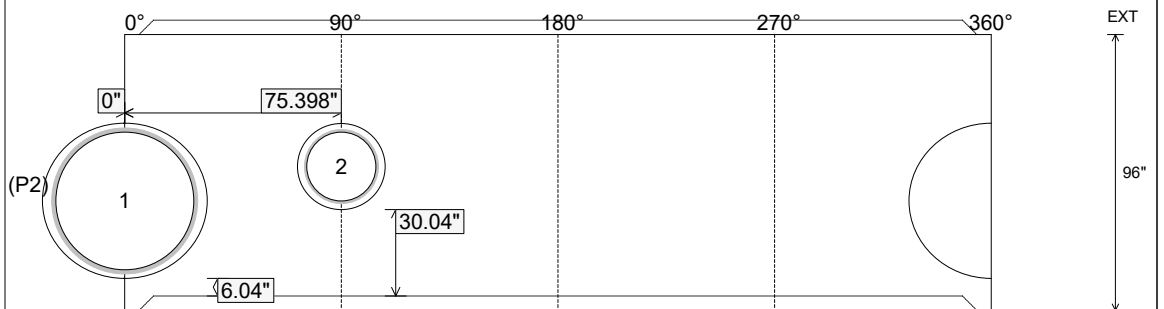

Coating (Int): Coating (Ext):	Seam Up: Tongue Seam Dn: Groove	Wall Thickness: 9" Floor Height: 0"	Height (Int): 96" Height (Ext): 96"	Weight (Net): 21554 lb Volume (Net): 5.51cu.yd
----------------------------------	------------------------------------	--	--	---