

**GENERAL NOTES:**

1. MANUFACTURED TO ASTM C-913 (LATEST REVISION)
2. CONCRETE: 5,000 PSI AT 28 DAYS
3. REINFORCEMENT PER ATTACHED DESIGN BY MATT CHILDS ENGINEERING, PLLC
4. WEIGHT: 36,433 LBS
5. HALLIDAY LADDER & SAFETY POST SUPPLIED BY ICAST
6. LIFTERS: 4 EA. 8CA18 CONAC A-ANCHORS FOR PLANT & FIELD HANDLING
7. XYPEX ADMIXTURE REQUIRED
8. KOR-N-SEAL BOOTS SUPPLIED BY OTHERS

OPENINGS						
PIPE ID	ANGLE	CL ELEV	INV ELEV	PIPE SIZE & TYPE	CONNECTOR	HOLE SIZE
P1	90	397.39	395.14	54" DUCTILE IRON	KOR-N-SEAL S206-62	Ø62"
P2	180	399.17	397.67	36" DUCTILE IRON	KOR-N-SEAL S206-42	Ø42"
P3	270	399.22	397.22	48" DUCTILE IRON	KOR-N-SEAL S206-54L	Ø54"
P4	90	412.67	412.00	16" FRP	KOR-N-SEAL S206-20	Ø20"

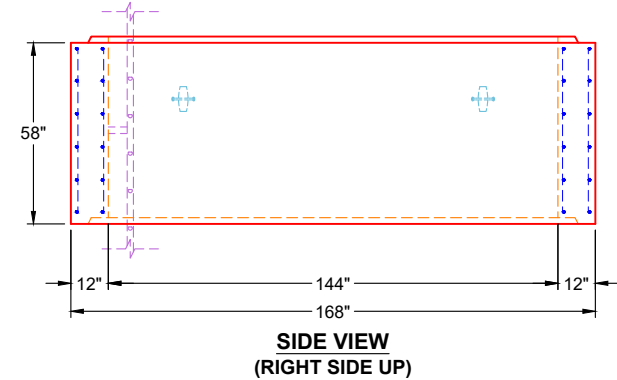
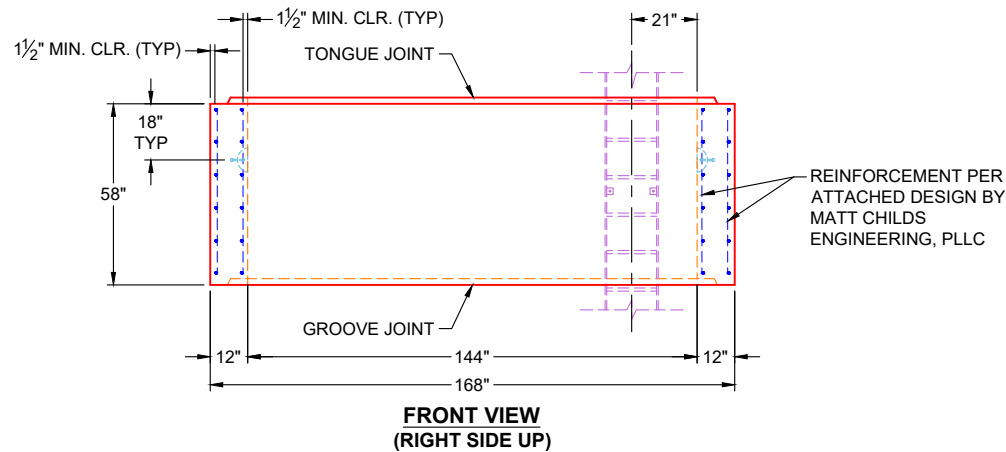

**PRODUCTION WORK ORDER**

PRODUCT I.D.: CVRX

DESCRIPTION: 144" X 144" X 58" RISER W/ XYPEX



**QUALITY CONTROL CHECKLIST**

- ALL DIMENSIONS CORRECT.
- LIFTERS INSTALLED.
- HOLE LOCATION(S) CORRECT.
- REINFORCING CORRECT.
- SURFACE QUALITY ACCEPTABLE.
- EDGES CHAMFERED.
- ALL PATCHWORK ACCEPTABLE.

PRODUCT VIEW: RIGHT SIDE UP

CUSTOMER: GARNEY COMPANIES, INC.

PLANT: BEAVER DAM, KY

PROJECT: EAST REGIONAL BANK PUMP STATION

WEIGHT: 36,433 LBS

STRUCTURE: GRINDER VAULT (PIECE 2)

TOP SECTION JOINT: TONGUE

ORDER NO: 25-1137B

BASE SECTION JOINT: GROOVE

PE: J.H. ROSS

DRAWING: K. CARDWELL

QC CHECK INITIALS:

DATE: 11/25/25

SCALE: NTS

PG. 1 OF 1

**DESIGN NOTE:**

HS20 LOADING - ASTM C890  
 CONCRETE 28 DAY COMPRESSIVE STRENGTH - 5000 PSI  
 REINFORCEMENT STEEL - 60,000 PSI  
 REBAR MIN SPLICE LENGTHS: #4-22" #5-28" #6-33"  
 PLACE 4-#4 BAR DIAGONAL AROUND OPENING(S)

STEEL REINFORCEMENT SHOWN BELOW SHALL BE CUT AS REQUIRED FOR WALL PENETRATIONS AND PRECAST JOINT LOCATIONS. PLEASE NOTE: DUE TO PRECAST PRODUCTION CONSTRAINTS, NO REINFORCING WILL BE CONTINUOUS ACROSS PRECAST JOINTS.

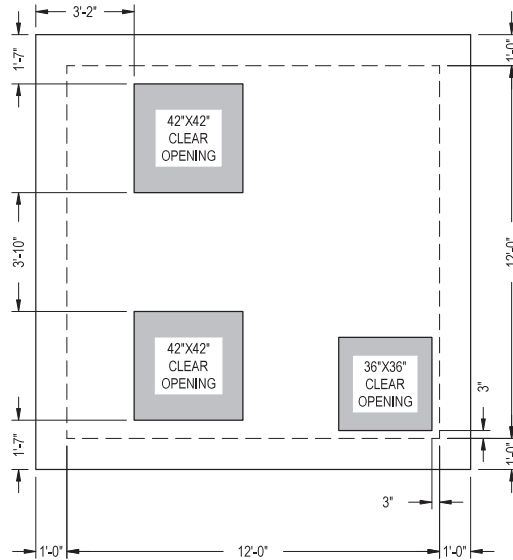

**PLAN VIEW**

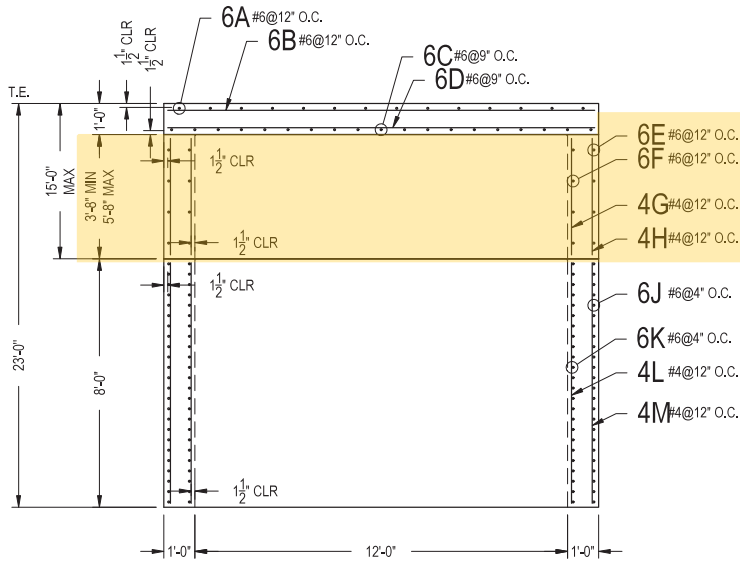

**FRONT VIEW**

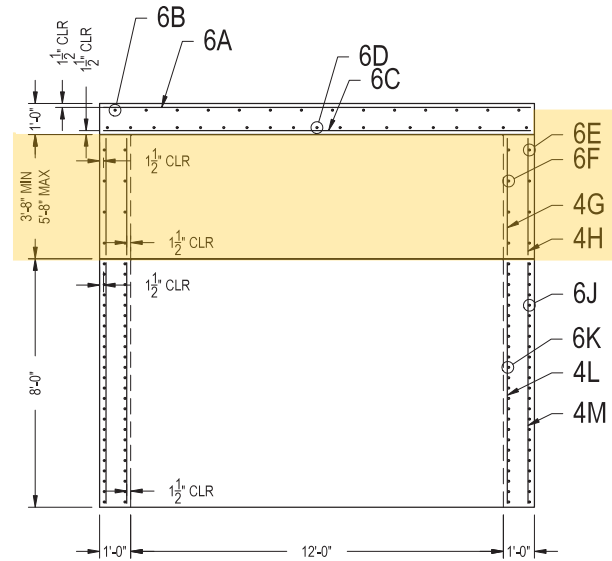

**RIGHT VIEW**

**REINFORCING STEEL SCHEDULE**

MARK	NO.	LENGTH	TYPE	lb/EA.	TOTAL LB	BENDING DIAGRAM
6A	14	13'-9"	STR.	20.6525	289,1350	
6B	14	13'-9"	STR.	20.6525	289,1350	
6C	19	13'-9"	STR.	20.6525	392,3975	
6D	19	13'-9"	STR.	20.6525	392,3975	
6E	VARIES	30'-3" (2)	BENT	45.4355	VARIES	
6F	VARIES	27'-8" (2)	BENT	41.5553	VARIES	
4G	50	VARIES	STR.	VARIES	VARIES	
4H	56	VARIES	STR.	VARIES	VARIES	
6J	24	30'-3" (2)	BENT	45.4355	2180,9040	
6K	24	27'-8" (2)	BENT	41.5553	1994,6560	
4L	50	7'-9"	STR.	5.1770	258,8500	
4M	56	7'-9"	STR.	5.1770	289,9120	



**12X12X22  
GRINDER  
VAULT**



MATT PHILLOS ENGINEERING PLLC  
 516 E. INTERSTATE 30, #1017  
 ROCKWALL, TX 75087

GRINDER VAULT  
 12'-0" x 12'-0"  
 GARNEY COMPANIES INC  
 EAST REGIONAL BANK PUMP STATION  
 DATE: 9/27/2023  
 PAGE: 1 OF 1

REVISIONS	DATE	BY	DESCRIPTION
A			
B			
C			
D			