

Job Name: 25-1137B - East Bank Regional Pump Station
 Job Location: Nashville, TN
 Contractor: Garney Companies, Inc.

Plant: Beaver Dam

Tech: J. Coppage

12/12/2025 10:08:47 AM

PC: J. Jarvis



Structure ID: Flow Meter Vault

P2 CVR-X

BOX RISER 8inW, Variable Ht w/Xypex FTB

- P4) 42" x 42" - HATCH (CAST FLUSH) - 3"
- P3) 72" x 108" - BX FLAT LID 8inW w/ XYPEX AND 2 HATCHES - 8"
- P2) 72" x 108" - BOX RISER 8inW, Variable Ht w/Xypex FTB - 97"
- P1) 72" x 108" - P.I.P. BY OTHERS - BTM SLAB - 0"
- 2) DOGHOUSE - 26"x26"

100 lb
 5536 lb
 24359 lb
 0 lb
 0 lb

 Structure Total: 29995 lb

Structure Notes:

1. MANUFACTURED TO ASTM C-913 (LATEST REVISION).
2. CONCRETE: 4,500 PSI AT 28 DAYS.
3. XYPEX ADMIXTURE REQUIRED.
4. REINFORCING: PER ASTM A615 (GRADE 60).
5. HALLIDAY F1H 42" X 42" HATCH AND HALLIDAY F1H 30" X 30" HATCH PROVIDED BY ICAST.
6. ALL HATCHES TO HAVE FALL PROTECTION.
7. TOP SLAB TO HAVE MINIMUM 1/4" CROWNED SLOPE PER FOOT AND A BRUSH FINISH.
8. HATCHES TO BE CAST IN TOP SLAB.

Rim: 417.25' Rim to Invert: 7.65' Slack: 0" Sump: 13.2' Step Position:

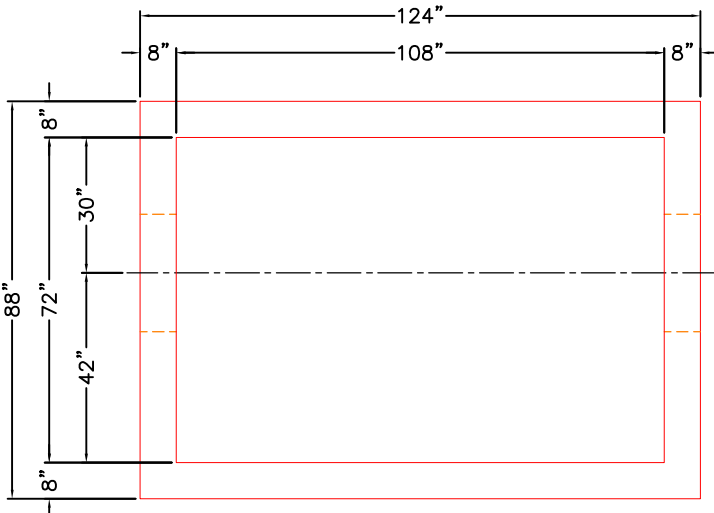

TOP VIEW

GENERAL NOTES:

1. MANUFACTURED TO ASTM C-913 (LATEST REVISION).
2. CONCRETE: 4,500 PSI AT 28 DAYS.
3. XYPEX ADMIXTURE REQUIRED.
4. REINFORCING: PER ASTM A615 (GRADE 60).
 HORIZONTALS - #5 BAR @ 6" O.C.
 HORIZONTALS TO BE "U" BARS.
 VERTICALS - #5 BAR @ 12" O.C.
5. WEIGHT: 24,359 LBS.

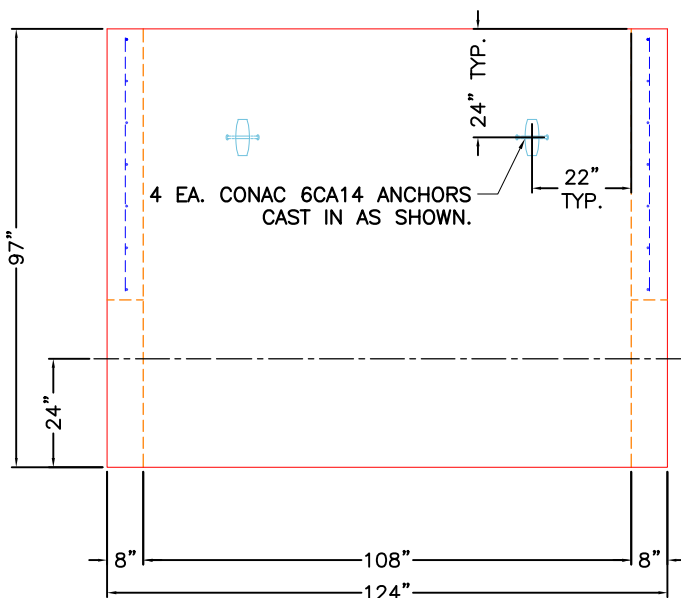

FRONT VIEW

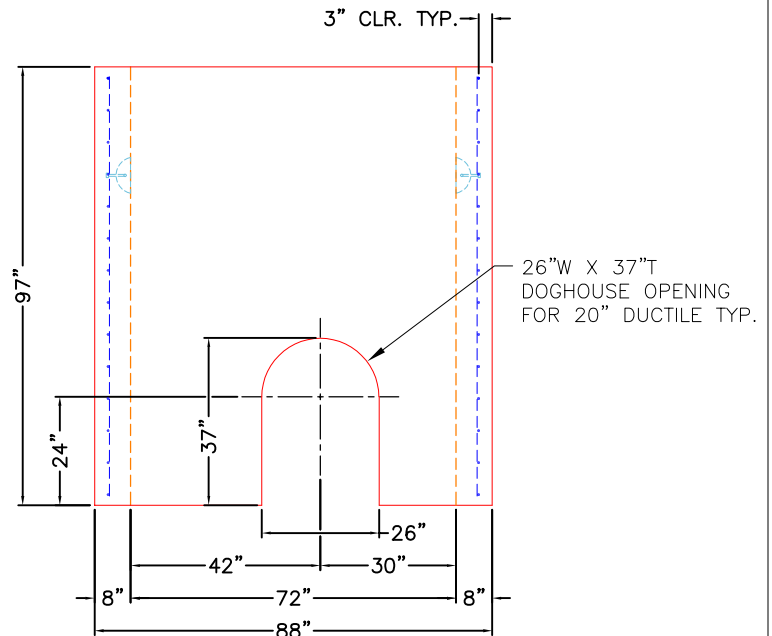

RIGHT VIEW

Coating (Int):
 Coating (Ext):

Seam Up: Flat
 Seam Dn: Flat

Wall Thickness: 8"
 Floor Height: 0"

Height (Int): 97"
 Height (Ext): 97"

Weight (Net): 24359 lb
 Volume (Net): 6.22cu.yd