

Job Name: 25-1137 - East Bank Regional Pump Station  
 Job Location: Nashville, TN  
 Contractor: Garney Companies, Inc.

Plant: Beaver Dam

Tech: M. Biliter

11/17/2025 8:40:36 AM

PC: J. Jarvis



**Structure ID: MH 003 3+50**

**P5 MH048CN30X**

**ECC XYPEX CONE w/ 24" HOLE**

- P7) 24" - CASTING HEIGHT - 7.50"
- P6) 24" - XYPEX GRADE RING - 4"
- P5) 48" - ECC XYPEX CONE w/ 24" HOLE - 30"
- P4) 48" - MH RISER w/XYPEX - 72"
- P3) 48" - MH RISER w/XYPEX - 72"
- P2) 72" - XYPEX MH FT REDUCER 48" HOLE - 15"
- P1) 72" - MH BASE w/XYPEX - 72"
- 1) JOINT WRAP PRIMER - CONSEAL CS-75 (1 gal.)
- 1) JOINT WRAP - 0.065"x6"x50' CONSEAL CS212
- 1) 72" - SAN. INV. CHANNEL - FULL HEIGHT
- 1) 72" - DBL 1"x14.5' Butyl (2x)
- 3) 48" - DBL 1"x14.5' Butyl (2x)
- 2) A-Lok - 1630
- 22) MH Step - 12"

Structure Notes:

1. PER ASTM C478 SPECIFICATIONS.
2. CONCRETE = 4,500 PSI AT 28 DAYS.
3. REINFORCING PER ASTM A615 (GRADE 60)
  - TOP (As .62) #5 BAR AT 6" C/C E.W.
  - WALLS (As .18) WWF OR EQUIV.
  - FLOOR (As .20) #4 BAR AT 12" C/C E.W. DOUBLE MAT
4. CASTING - JBS 1123 WT F/G "SANITARY" BY ICAST.

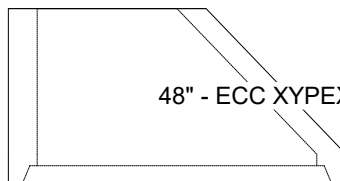
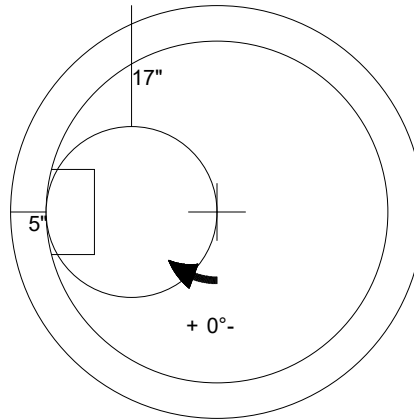

48" - ECC XYPEX CONE w/ 24" HOLE - 30" - (P5)

Coating (Int):  
 Coating (Ext):

Seam Up: Flat  
 Seam Dn: Groove

Wall Thickness: 5"

Height (Ext): 30"

Weight (Net): 2050 lb  
 Volume (Net): 0.41cu.yd