

Job Name: 25-1110 Automated Record Fire Plus Range
Job Location:
Contractor: Birmingham Industrial Construction

Plant: Beaver Dam
1/30/2026 7:52:59 AM

Tech: J. Coppage
PC: A. Chambers



Structure ID: SAT-2 - SAT Down Range Power Center

P6 CVBS

5' x 5' x 6" Concrete Pad - 5' x 5' x 6" Concrete Pad - 60" x 60"

GENERAL NOTES:

1. MANUFACTURED TO ASTM C-913 (LATEST REVISION).
2. CONCRETE: 4,000 PSI AT 28 DAYS.
3. REINFORCING: #5 BAR @ 8" C-C E.W. PER ASTM A615 (GRADE 60).
4. 1/2" CHAMFER ON ALL EXPOSED EDGES.
5. WEIGHT:
TOTAL - 1,813 LBS EACH
6. 1 TOTAL REQUIRED

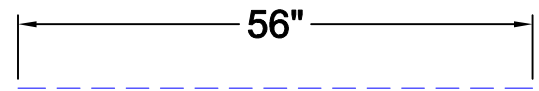
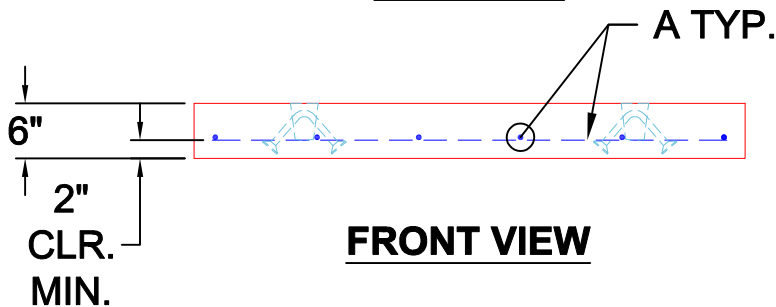
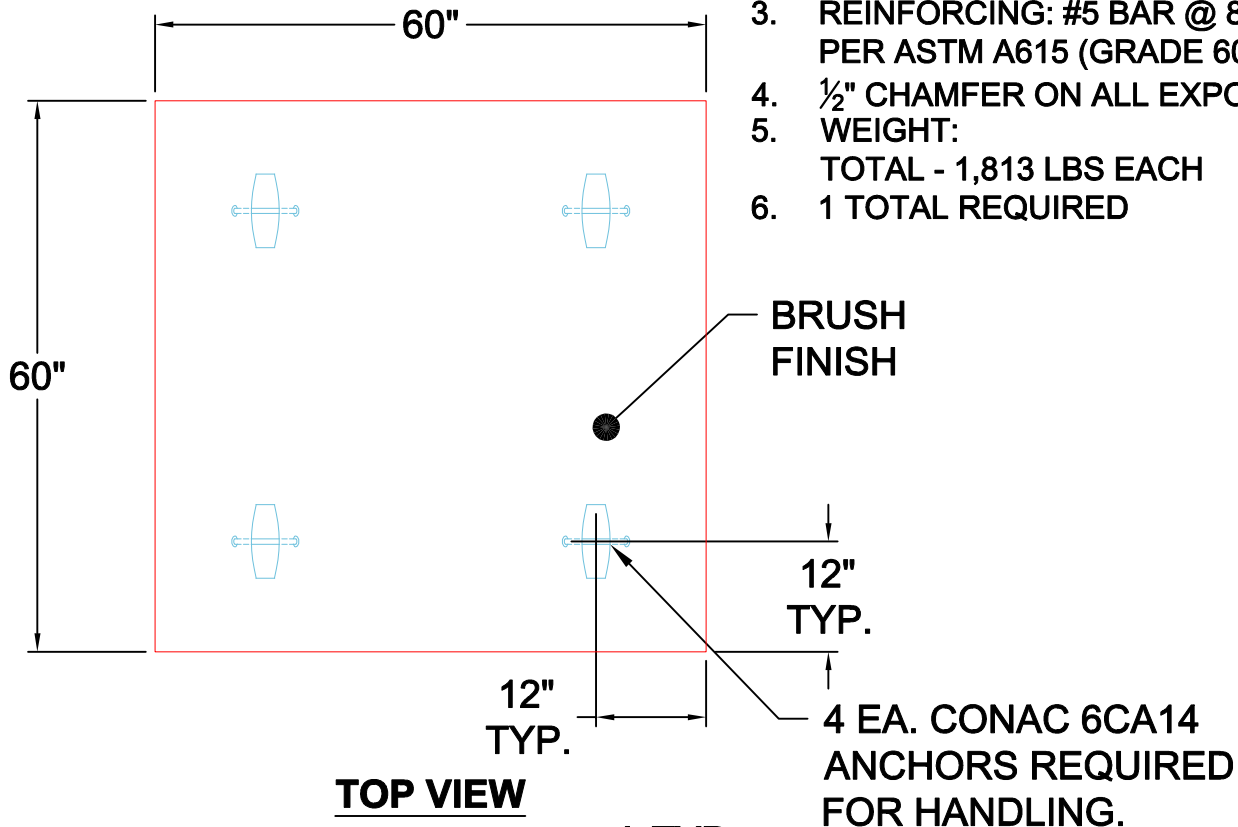

BAR - A
#5 BAR (GRADE 60)
(18) - TOTAL REQUIRED