

Job Name: 25-1026 Thompson's Station WWTP (Ph. 2)
 Job Location: Thompson's Station
 Contractor: W&O Construction

Plant: Beaver Dam

Tech: J. Coppage

10/15/2025 2:03:23 PM

PC: A. Chambers



Structure ID: SSMH-B

P3 MH048RS72X

MH RISER w/XYPEX

- P5) 24" - CASTING HEIGHT - 7"
- P4) 48" - ECC XYPEX CONE w/ 24" HOLE - 30"
- P3) 48" - MH RISER w/XYPEX - 72"
- P2) 48" - MH RISER w/XYPEX - 72"
- P1) 48" - MH BASE w/XYPEX - 42"
- 1) JOINT WRAP - 0.065"x6"x50' CONSEAL CS212
- 1) JOINT WRAP PRIMER - CONSEAL CS-75 (1 gal.)
- 1) 48" - MH INVERT CHANNEL w/XYPEX - FULL HEIGHT
- 1) CASTING - JBS 1150 F/C SANITARY
- 3) 48" - Conseal CS-102 1.00" (Double)
- 1) Kor-N-Seal2 - S206-22L
- 1) Kor-N-Seal2 - S206-18L
- 1) Kor-N-Seal2 - S206-22

- Structure Notes:**
1. JBS-1150 SANITARY PROVIDED BY ICAST.
 2. PER ASTM C478 SPECIFICATIONS.
 3. CONCRETE = 4,000 PSI AT 28 DAYS.
 4. REINFORCING PER ASTM A615 (GRADE 60).
 - CONE (As .12)
 - RISER/WALLS (As .12)
 - FLOOR (As .31) #5 BARS AT 12" C.C.E.W.

0 lb
 1981 lb
 5030 lb
 5030 lb
 3826 lb
 0 lb
 0 lb
 1440 lb
 250 lb
 0 lb
 6 lb
 6 lb
 6 lb
 6 lb

Structure Total: 17576 lb

Rim: 738' Rim to Invert: 18.6' Slack: 2.2" Sump: 2" Step Position: 353°

Position	Elev	Angle	Ext. (cw)	Pipe	Pipe OD	Connector	Hole	Horz Size	Up (L)	Offset
Invert 1										
Invert 2										
Invert 3										
Invert 4										
Invert 5										
Invert 6										
Invert 7										
Invert 8										

RIGHT-SIDE UP VIEW (int. dimensions)

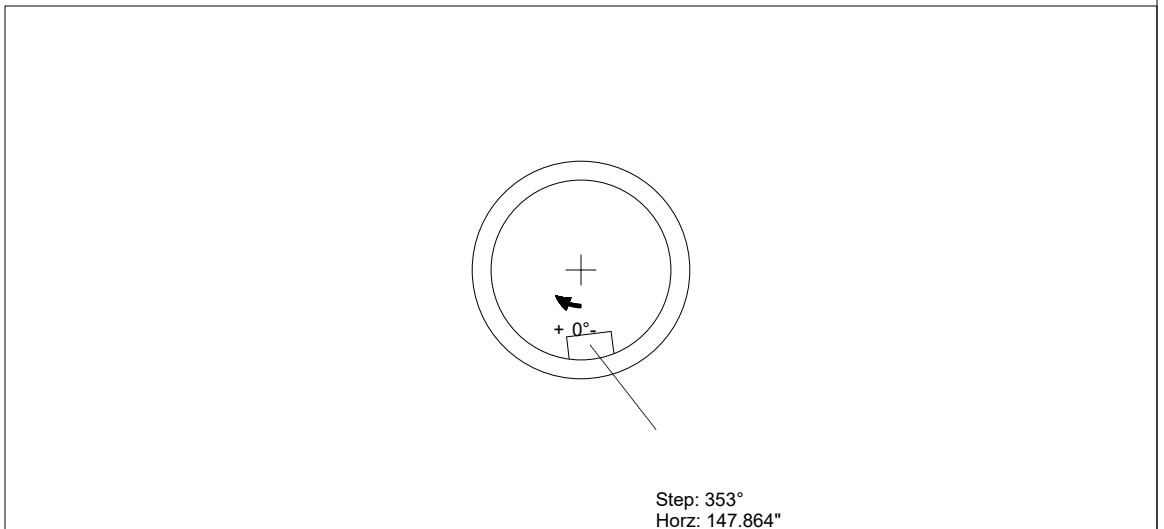
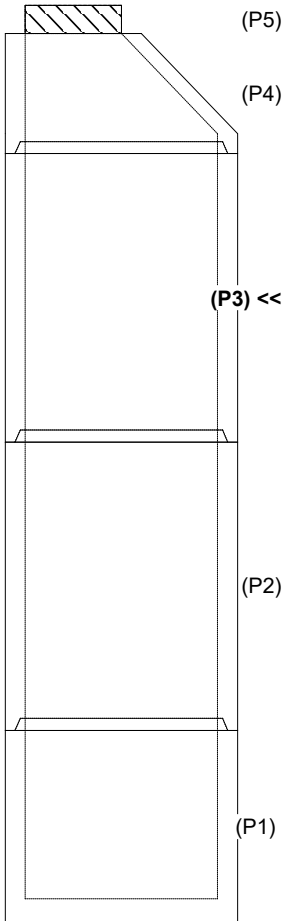

INSIDE WALL DIMENSIONS



Coating (Int): Coating (Ext):	Seam Up: Tongue Seam Dn: Groove	Wall Thickness: 5" Floor Height: 0"	Height (Int): 72" Height (Ext): 72"	Weight (Net): 5030 lb Volume (Net): 1.28cu.yd
----------------------------------	------------------------------------	--	--	--