

TOP VIEW

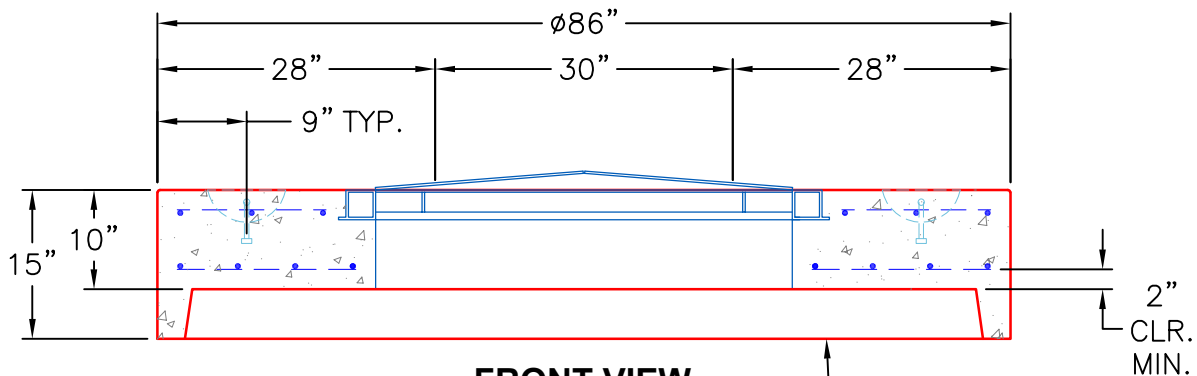

FRONT VIEW

NOTES:

1. MANUFACTURED TO ASTM C-478 (LATEST REVISION).
2. CONCRETE: 5,000 PSI AT 28 DAYS.
3. REINFORCING: PER ASTM A615 (GRADE 60)
TOP MAT - #5 BAR @ 12" C-C E.W.
BTM MAT - #5 BAR @ 6" C/C E.W.
4. WEIGHT: 5,436 LBS.
5. XYPEX ADMIXTURE REQUIRED.
6. 42" X 42" HALLIDAY S2R HATCH BY ICAST.
7. HATCH TO BE CAST INTO TOP SLAB.

CONCRETE TO RECEIVE XYPEX ADMIXTURE

PRODUCTION WORK ORDER		PRODUCT I.D.: MH072LD15XS	DESCRIPTION: ø72" MH TOP SLAB 15" THICK W/ 42" X 42" HATCH	
	QUALITY CONTROL CHECKLIST	PRODUCT VIEW: RIGHT SIDE UP	CUSTOMER: W&O CONSTRUCTION	
	<input type="checkbox"/> ALL DIMENSIONS CORRECT.	PLANT: BEAVER DAM, KY.	PROJECT: THOMPSON'S STATION WWTP (PH. 2)	
	<input type="checkbox"/> LIFTERS INSTALLED.	WEIGHT: 3,775 LBS.	STRUCTURE: METERING MANHOLE	
	<input type="checkbox"/> HATCH LOCATION CORRECT.	TOP SECTION JOINT: N/A	ORDER NO: 25-1026	
	<input type="checkbox"/> REINFORCING CORRECT.	BASE SECTION JOINT: BELL	PC: A. CHAMBERS	DRAWING: J. COPPAGE
<input type="checkbox"/> ALL PATCHWORK ACCEPTABLE.	QC CHECK INITIALS:	DATE: 10/20/25	SCALE: NTS	PG. 1 of 1
<input type="checkbox"/> LIGHT BRUSHED FINISH ON TOP.				
<input type="checkbox"/> JOINT INSTALLED.				