

Job Name: 25-1026 Thompson's Station WWTP (Ph. 2)
Job Location: Thompson's Station
Contractor: W&O Construction

PC: A. Chambers
 TECH: J. Coppage
 Plant: Beaver Dam



Structure ID: LIFT STATION

Spec: Sanitary
 Type: Wet Well w/Xypex
 Size: 144"

Rim: 738.25'
 Invert: 719.33'
 Rim to Invert: 18.92'

Sump: 141.96"
 Floor (Top): 707.5'
 Floor Height: 12"

Floor (Bot): 706.5'
 Overall Height: 30.583'
 Slack: 14"

Structure Notes:

REINFORCING PER ASTM A615 (GRADE 60).
 - RISER/WALLS (As .30) 3 WRAPS WWF

STRUCTURE SUMMARY:

P5) 144" - MH RISER w/XYPEX - 78"	41232 lb
P4) 144" - MH RISER w/XYPEX - 96"	51595 lb
P3) 144" - MH RISER w/XYPEX - 96"	51236 lb
P2) 144" - MH RISER Custom Ht, w/XYPEX - 85"	45734 lb
P1) 144" - MH BASE SLAB w/XYPEX - 12"	22733 lb
1) JOINT WRAP - 12" WD x 144" MAC WRAP	0 lb
5) 144" - BUTYL 1.25" CS-231 (DBL = 90' per joint)	0 lb
3) Hole - 16	0 lb
1) PSX - 8QRS DD	6 lb
1) Kor-N-Seal2 - S206-22L	6 lb
Structure Total:	212544 lb

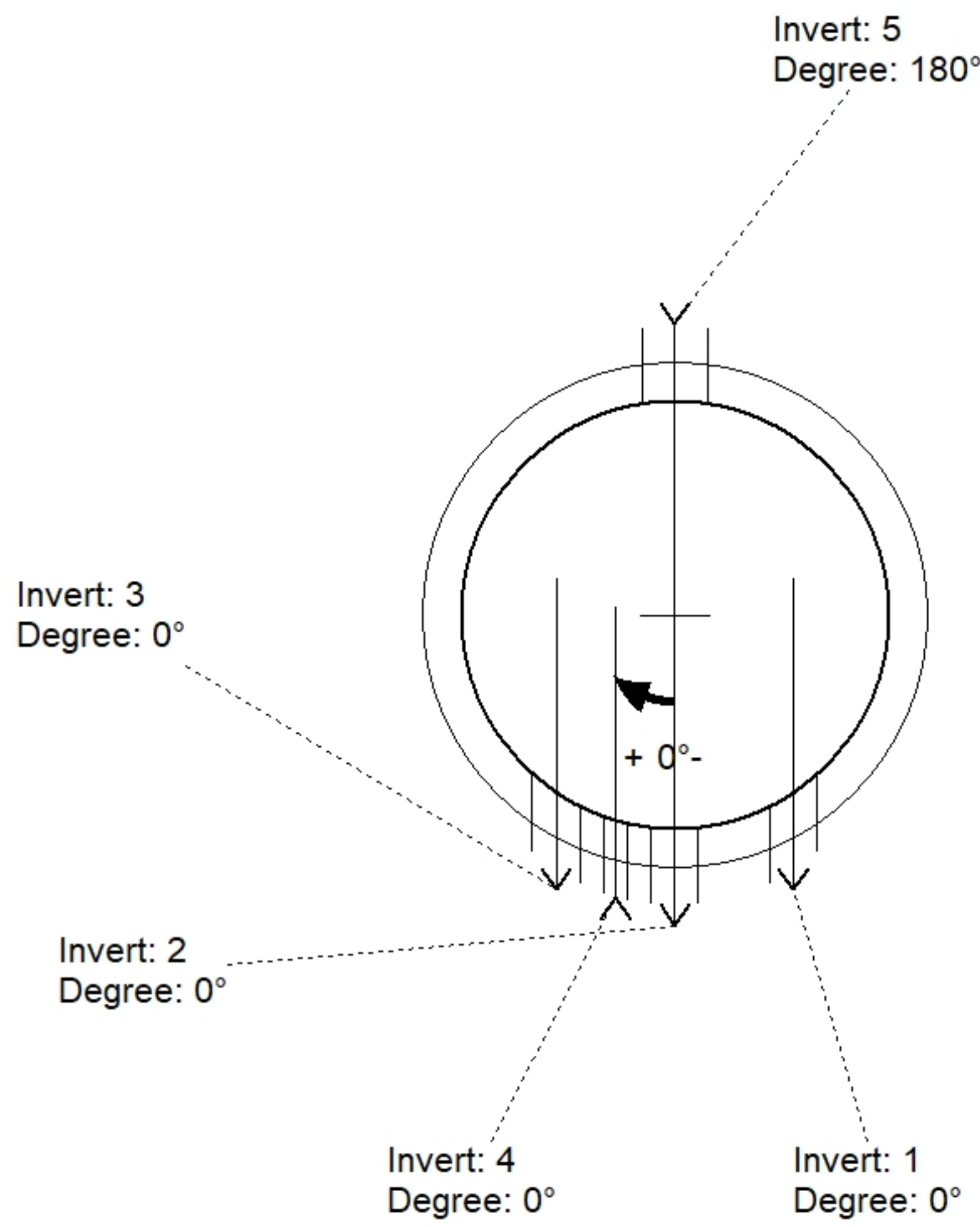

Position	Elev	Angle	Pipe	Pipe OD	Hole	Connector	Up (")	Ref
Rim	738.25'							
Reducer								
Invert 1	731.89'	0°	10" DI	11.1"	16"	Hole 16	6.68"	P5
Invert 2	731.89'	0°	10" DI	11.1"	16"	Hole 16	6.68"	P5
Invert 3	731.89'	0°	10" DI	11.1"	16"	Hole 16	6.68"	P5
Invert 4	728.25'	0°	2" PVC SCH40	2.375"	8"	PSX 8QRS DD	59.024"	P4
Invert 5	719.33'	180°	18" DI	19.5"	22"	Kor-N-Seal2 S206-22L	48.96"	P3
Invert 6								
Invert 7								
Invert 8								

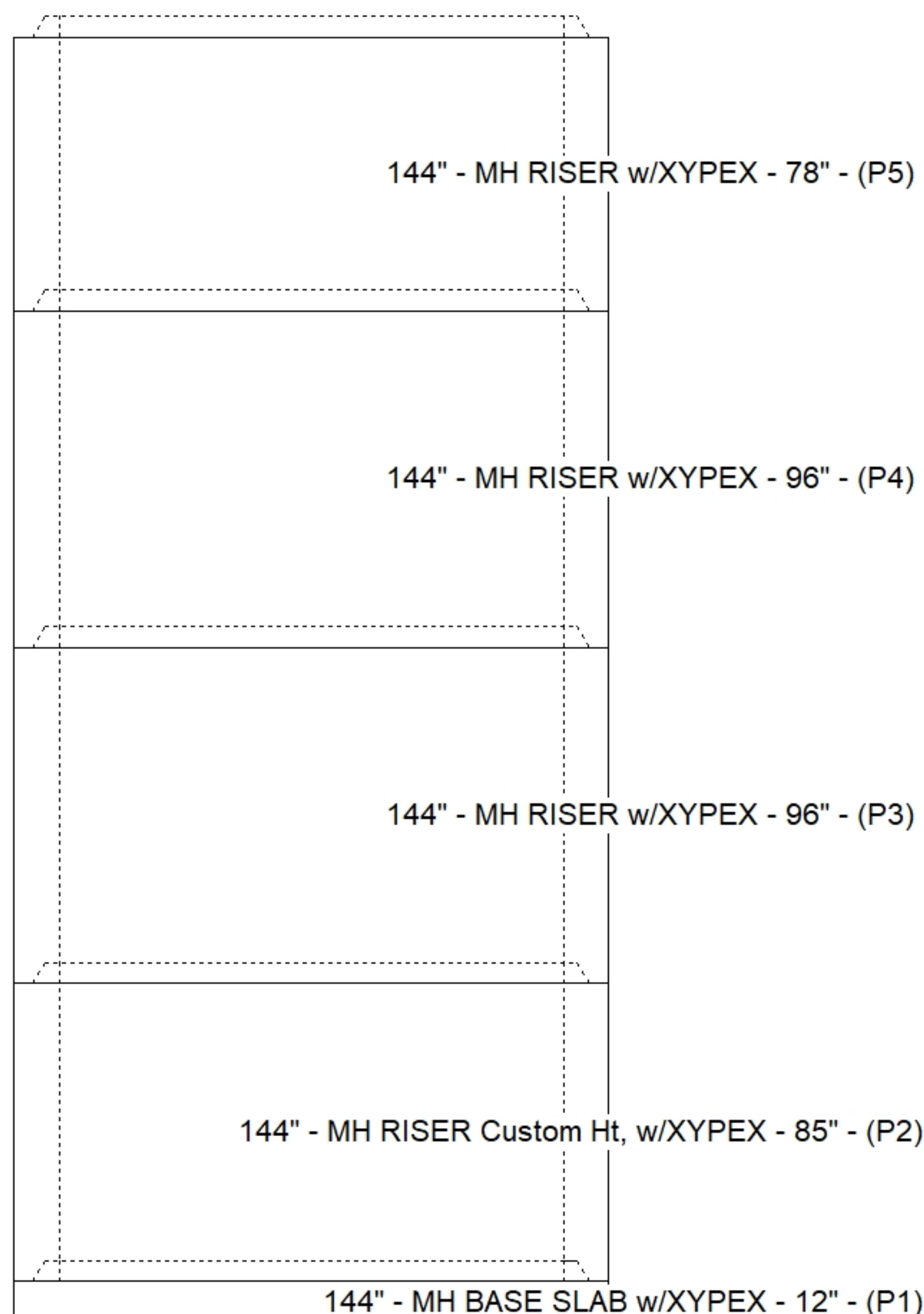

Default - Interior Dimensions

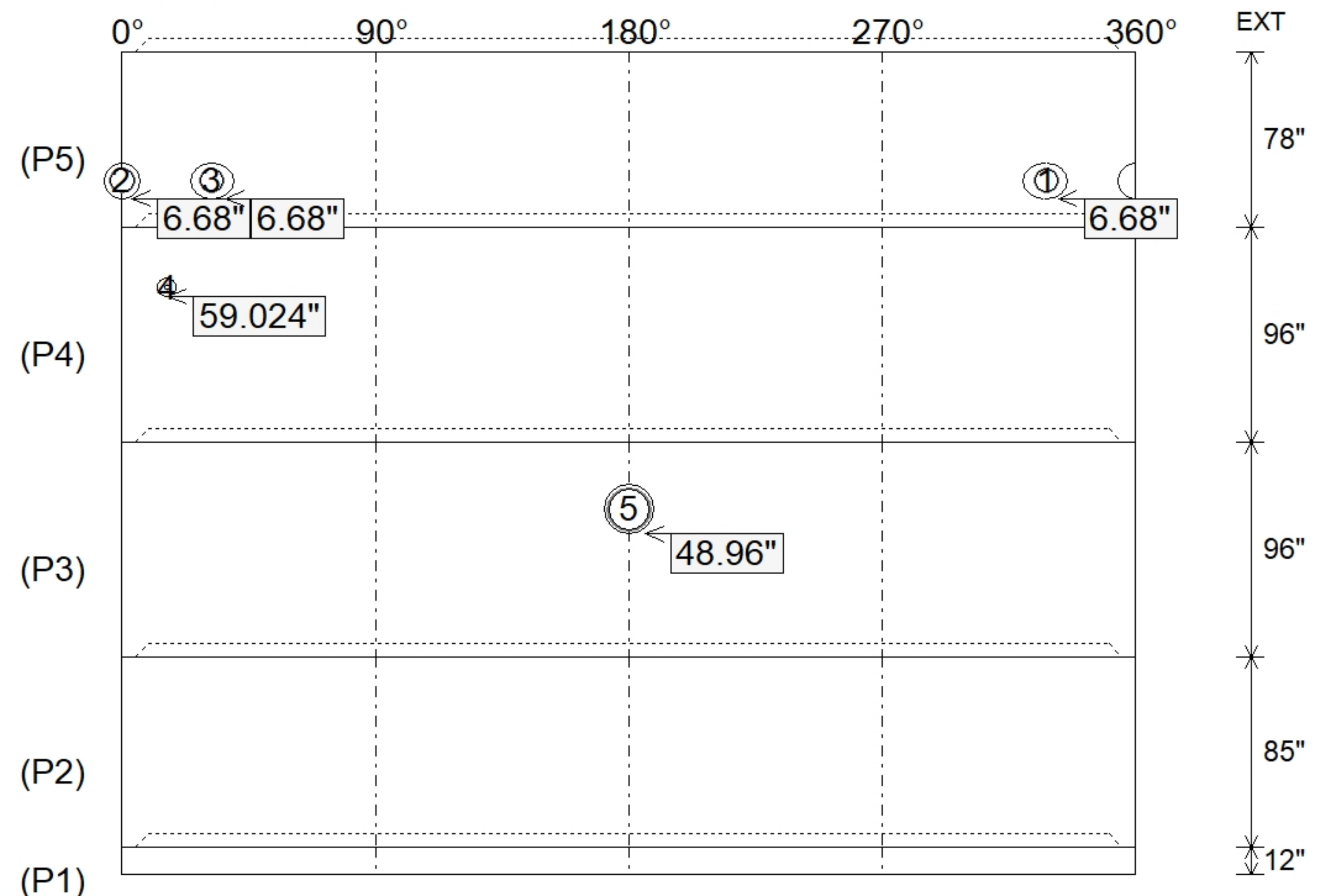

Submittal Drawing
 11/18/2025 7:36:17 AM

SUBMITTAL
 APPROVED BY: