

Job Name: 25-1026 Thompson's Station WWTP (Ph. 2)
 Job Location: Thompson's Station
 Contractor: W&O Construction

Plant: Beaver Dam

Tech: J. Coppage

10/15/2025 2:03:27 PM

PC: A. Chambers



Structure ID: LIFT STATION

P5 MH144RS78X

MH RISER w/XYPEX

P5) 144" - MH RISER w/XYPEX - 78"	41232 lb
P4) 144" - MH RISER w/XYPEX - 96"	51595 lb
P3) 144" - MH RISER w/XYPEX - 96"	51236 lb
P2) 144" - MH RISER Custom Ht, w/XYPEX - 85"	45734 lb
P1) 144" - MH BASE SLAB w/XYPEX - 12"	22733 lb
1) JOINT WRAP - 12" WD x 144" MAC WRAP	0 lb
5) 144" - BUTYL 1.25" CS-231 (DBL = 90' per joint)	0 lb
3) Hole - 16	0 lb
1) PSX - 8QRS DD	6 lb
1) Kor-N-Seal2 - S206-22L	6 lb
Structure Total:	212544 lb

Structure Notes:
 REINFORCING PER ASTM A615 (GRADE 60).
 - RISER/WALLS (As .30) 3 WRAPS WWF

Rim: 738.25' Rim to Invert: 18.92' Slack: 14" Sump: 141.96" Step Position:

Position	Elev	Angle	Ext. (cw)	Pipe	Pipe OD	Connector	Hole	Horz Size	Up ()	Offset
Invert 1	731.89'	0°	-41.646"	10" DI	11.1"	Hole 16	16"	19.381"	6.68"	-40"
Invert 2	731.89'	0°	0"	10" DI	11.1"	Hole 16	16"	16.033"	6.68"	0"
Invert 3	731.89'	0°	41.646"	10" DI	11.1"	Hole 16	16"	19.381"	6.68"	40"
Invert 4										
Invert 5										
Invert 6										
Invert 7										
Invert 8										

RIGHT-SIDE UP VIEW (int. dimensions)

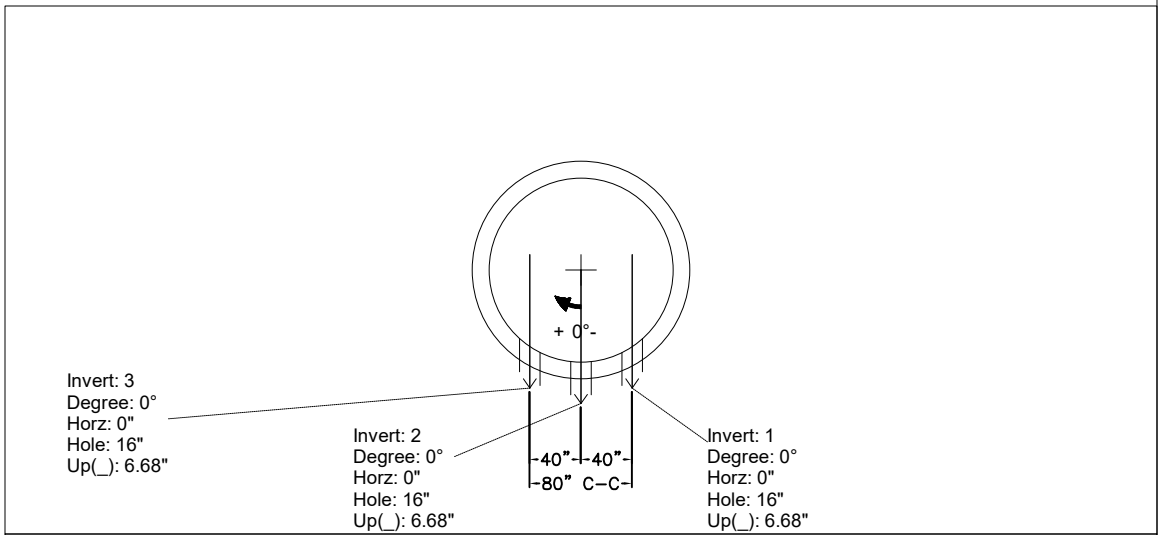
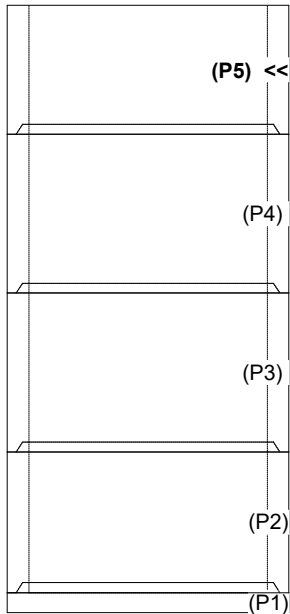

INSIDE WALL DIMENSIONS

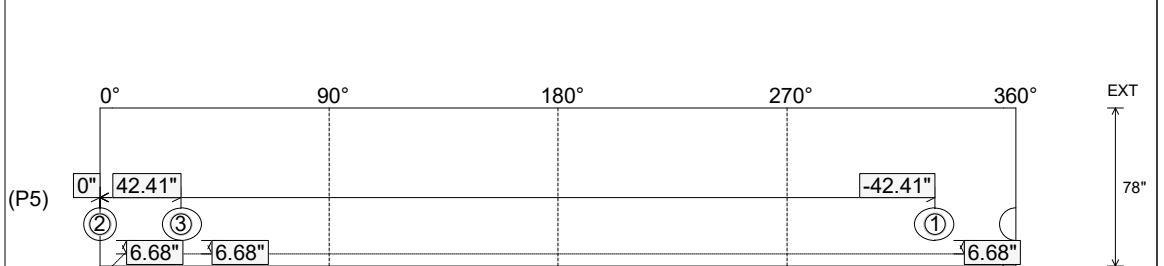

Coating (Int): Coating (Ext):	Seam Up: Flat Seam Dn: Groove	Wall Thickness: 13" Floor Height: 0"	Height (Int): 78" Height (Ext): 78"	Weight (Net): 41232 lb Volume (Net): 10.53cu.yd
----------------------------------	----------------------------------	---	--	--