

Job Name: 25-1026 Thompson's Station WWTP (Ph. 2)
 Job Location: Thompson's Station
 Contractor: W&O Construction

Plant: Beaver Dam

Tech: J. Coppage

10/15/2025 2:03:25 PM

PC: A. Chambers



Structure ID: LIFT STATION

P3 MH144RS96X

MH RISER w/XYPEX

| | |
|--|------------------|
| P5) 144" - MH RISER w/XYPEX - 78" | 41232 lb |
| P4) 144" - MH RISER w/XYPEX - 96" | 51595 lb |
| P3) 144" - MH RISER w/XYPEX - 96" | 51236 lb |
| P2) 144" - MH RISER Custom Ht, w/XYPEX - 85" | 45734 lb |
| P1) 144" - MH BASE SLAB w/XYPEX - 12" | 22733 lb |
| 1) JOINT WRAP - 12" WD x 144" MAC WRAP | 0 lb |
| 5) 144" - BUTYL 1.25" CS-231 (DBL = 90' per joint) | 0 lb |
| 3) Hole - 16 | 0 lb |
| 1) PSX - 8QRS DD | 6 lb |
| 1) Kor-N-Seal2 - S206-22L | 6 lb |
| Structure Total: | 212544 lb |

Structure Notes:
 REINFORCING PER ASTM A615 (GRADE 60).
 - RISER/WALLS (As .30) 3 WRAPS WWF

Rim: 738.25' Rim to Invert: 18.92' Slack: 14" Sump: 141.96" Step Position:

| Position | Elev | Angle | Ext. (cw) | Pipe | Pipe OD | Connector | Hole | Horz Size | Up () | Offset |
|----------|---------|-------|-----------|--------|---------|----------------------|------|-----------|--------|--------|
| Invert 1 | | | | | | | | | | |
| Invert 2 | | | | | | | | | | |
| Invert 3 | | | | | | | | | | |
| Invert 4 | | | | | | | | | | |
| Invert 5 | 719.33' | 180° | 267.035" | 18" DI | 19.5" | Kor-N-Seal2 S206-22L | 22" | 22.086" | 48.96" | 0" |
| Invert 6 | | | | | | | | | | |
| Invert 7 | | | | | | | | | | |
| Invert 8 | | | | | | | | | | |

RIGHT-SIDE UP VIEW (int. dimensions)

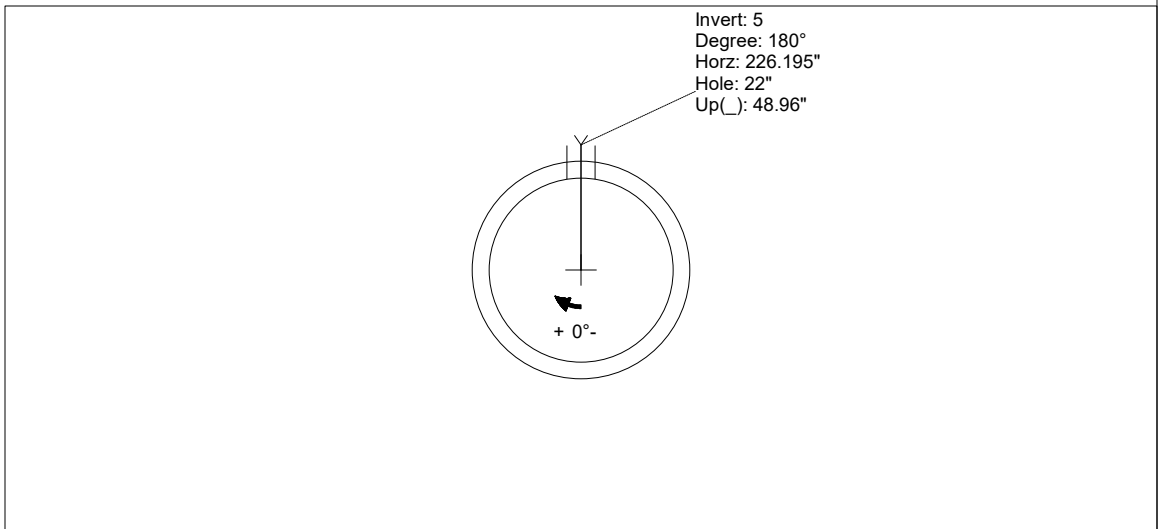
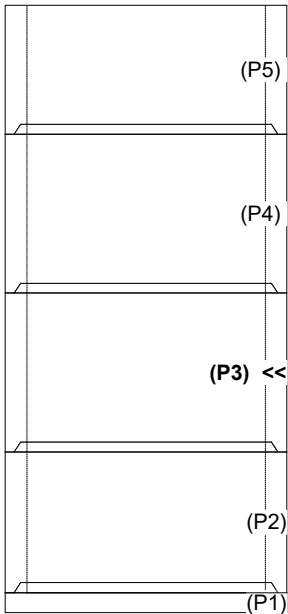

INSIDE WALL DIMENSIONS

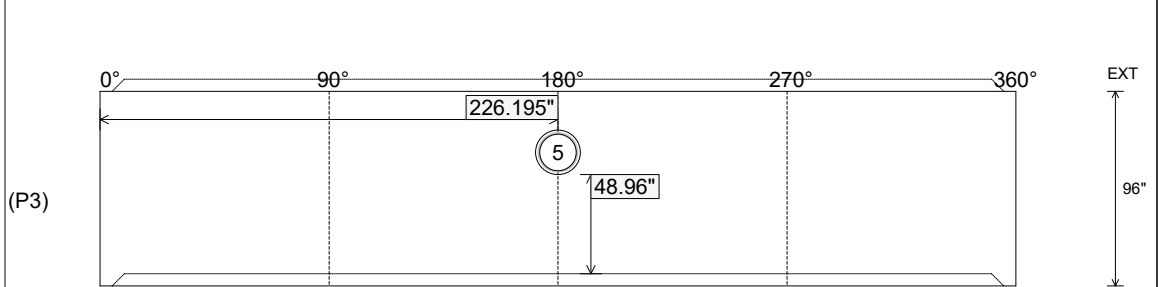

Coating (Int):
 Coating (Ext):

Seam Up: Tongue
 Seam Dn: Groove

Wall Thickness: 13"
 Floor Height: 0"

Height (Int): 96"
 Height (Ext): 96"

Weight (Net): 51236 lb
 Volume (Net): 13.09cu.yd