

Job Name: 25-1026 Thompson's Station WWTP (Ph. 2)
 Job Location: Thompson's Station
 Contractor: W&O Construction

Plant: Beaver Dam

Tech: J. Coppage

10/15/2025 2:02:58 PM

PC: A. Chambers



Structure ID: ARV

P1 MH072DHRS54X

MH DH RISER Custom Ht, w/YYPEX

- P2) 72" - XYPEX MH FLAT TOP SPECIAL - 15"
- P1) 72" - MH DH RISER Custom Ht, w/YYPEX - 62"
- 1) CASTING - JBS 1154 F/C SANITARY
- 1) 72" - Conseal CS-102 1.00" (Double)
- 2) DOGHOUSE - 18"x24"

- Structure Notes:**
1. JBS-1154 SANITARY PROVIDED BY ICAST.
 2. PER ASTM C478 SPECIFICATIONS.
 3. CONCRETE = 4,000 PSI AT 28 DAYS.
 4. REINFORCING PER ASTM A615 (GRADE 60).
 - TOP SLAB (As .62) #5 BARS AT 6" C.C.E.W..
 - RISER/WALLS (As .18)
 - FLOOR (As .37) #5 BARS AT 10" C.C.E.W.
 5. CASTING FRAME TO BE CAST INTO THE TOP SLAB.

Structure Total: 16143 lb

Rim: 738' Rim to Invert: 6' Slack: 0" Sump: 5" Step Position: 180°

| Position | Elev | Angle | Ext. (cw) | Pipe | Pipe OD | Connector | Hole | Horz Size | Up (⌋) | Offset |
|----------|------|-------|-----------|--------|---------|------------------|-----------|-----------|--------|--------|
| Invert 1 | 732' | 90° | 67.544" | 14" DI | 15.3" | DOGHOUSE 18"x24" | 18" x 24" | 18.193" | 0" | 0" |
| Invert 2 | 732' | 270° | 202.633" | 14" DI | 15.3" | DOGHOUSE 18"x24" | 18" x 24" | 18.193" | 0" | 0" |
| Invert 3 | | | | | | | | | | |
| Invert 4 | | | | | | | | | | |
| Invert 5 | | | | | | | | | | |
| Invert 6 | | | | | | | | | | |
| Invert 7 | | | | | | | | | | |
| Invert 8 | | | | | | | | | | |

RIGHT-SIDE UP VIEW (int. dimensions)

UPSIDE-DOWN VIEW (int. dimensions)

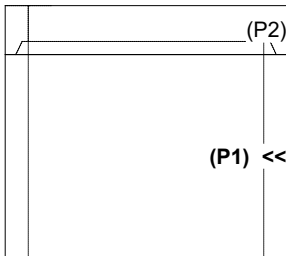
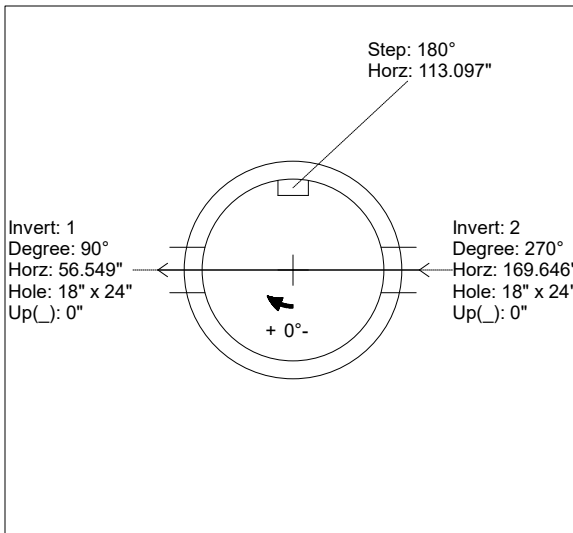

INSIDE WALL DIMENSIONS

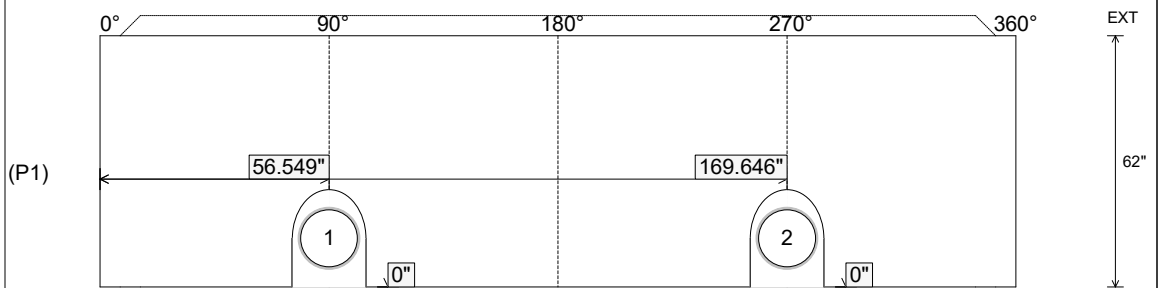

Coating (Int):
 Coating (Ext):

Seam Up: Tongue
 Seam Dn: Flat

Wall Thickness: 7"
 Floor Height: 0"

Height (Int): 62"
 Height (Ext): 62"

Weight (Net): 8581 lb
 Volume (Net): 2.19cu.yd