

Job Name: 25-1008D - MSU Science & Engineering Bldg
 Job Location: Morehead, KY
 Contractor: Lagco Inc.

Plant: 100

Tech: J. Horsley

2/27/2026 6:54:47 AM

PC: C. Goff



Structure ID: K3-2 ST-MH

P1 MH048BA36

MH BASE T/n

- P5) 24" - CASTING HEIGHT - 7"
- P4) 24" - GRADE RING F/F - 4"
- P3) 48" - MH FLAT TOP w/ 24" ECC Hole F/G - 12"
- P2) 48" - MH RISER SPECIAL T/G - 48"
- P1) 48" - MH BASE T/n - 36"
- 1) CASTING - HOE MC-315 F/C Storm
- 1) 48" - Conseal CS-102 1.00"
- 2) Hole - 16
- 7) MH Step ML-10-TDS-NCR - 10"

0 lb
 270 lb
 1561 lb
 3267 lb
 3759 lb
 258 lb
 0 lb
 0 lb
 0 lb

 Structure Total: 9116 lb

- Structure Notes:**
1. PER ASTM C-478 SPECIFICATIONS
 2. CONCRETE: 4,000 PSI AT 28 DAYS
 3. REINFORCEMENT: PER ASTM A615
 4. NO STORM INVERT
 5. STEPS AT 264 DEGREES
 6. HOE MC-315 FRAME & COVER "STORM" SUPPLIED BY ICAST

Rim: 755' Rim to Invert: 9' Slack: 1" Sump: 0" Step Position: 264°

Position	Elev	Angle	Ext. (cw)	Pipe	Pipe OD	Connector	Hole	Horz Size	Up ()	Offset
Invert 1	746'	0°	0"	12" HDPE	14.5"	Hole 16	16"	16.312"	-1.25"	0"
Invert 2										
Invert 3										
Invert 4										
Invert 5										
Invert 6										
Invert 7										
Invert 8										

RIGHT-SIDE UP VIEW (int. dimensions)

UPSIDE-DOWN VIEW (int. dimensions)

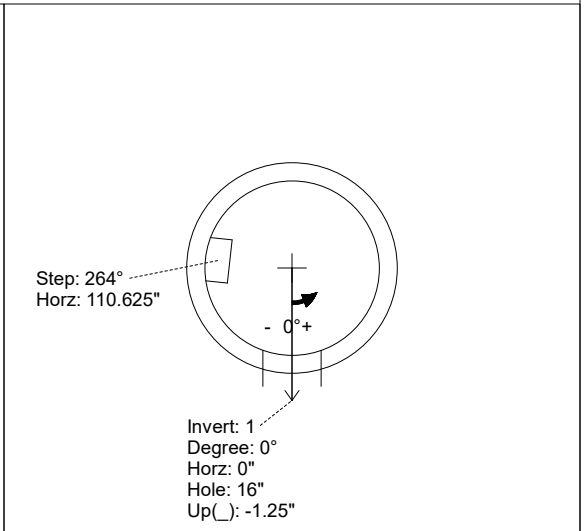
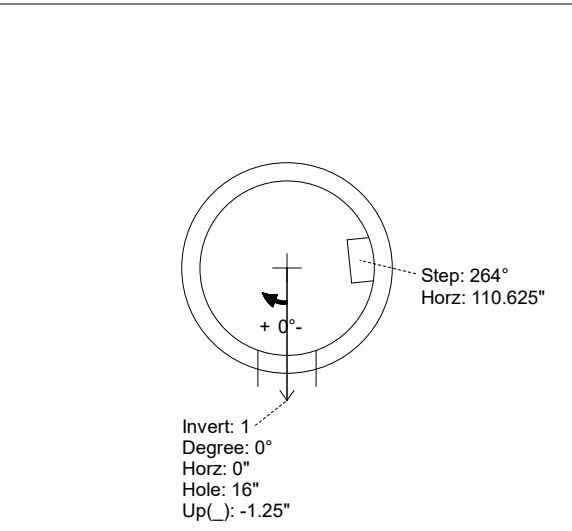
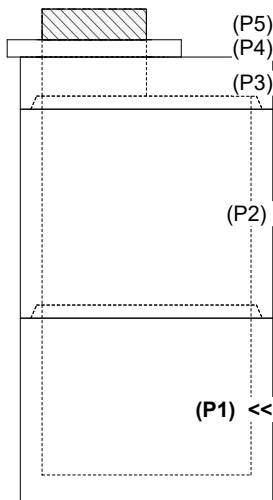

INSIDE WALL DIMENSIONS

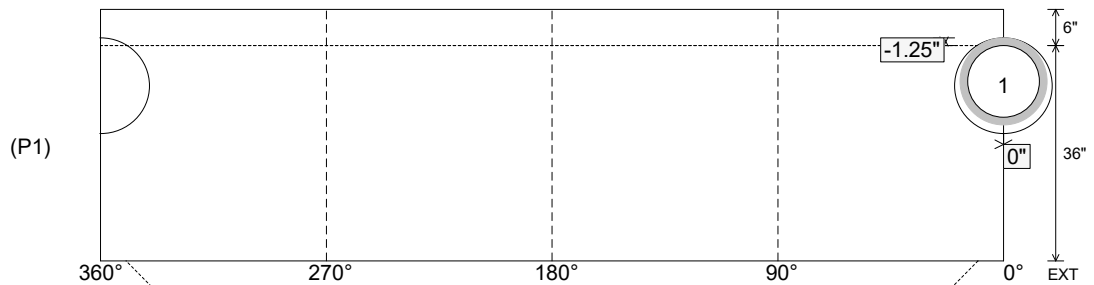

Coating (Int):
 Coating (Ext):

Seam Up: Tongue
 Seam Dn: n/a

Wall Thickness: 5"
 Floor Height: 6"

Height (Int): 36"
 Height (Ext): 42"

Weight (Net): 3759 lb
 Volume (Net): 0.96cu.yd