

GENERAL NOTES:

1. PER ASTM C-913 (LATEST REVISION) SPECS
2. CONCRETE: 5,000 PSI AT 28 DAYS
3. REINFORCEMENT: #5 BAR @ 12" C.C. E.W. (GRADE 60) - 2" MIN. REBAR CLEARANCE (TYP)
4. TOTAL WEIGHT: 5,315 LBS
 - FIRST POUR: 3,665 LBS
 - SECOND POUR: 1,650 LBS
5. ALL LIFT POINTS & PIPE OPENINGS TO BE GROUTED BY CONTRACTOR

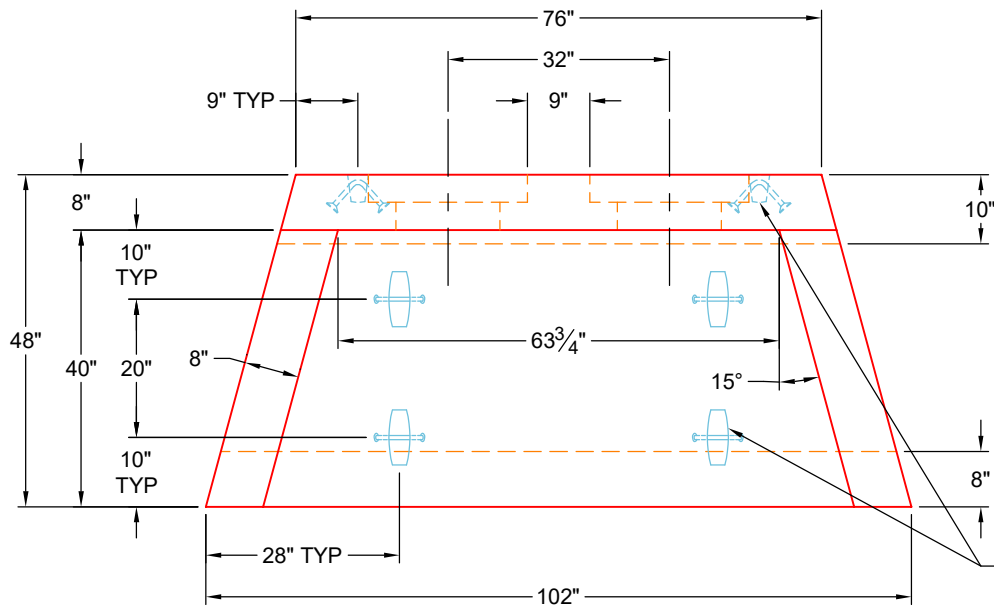

PLAN VIEW

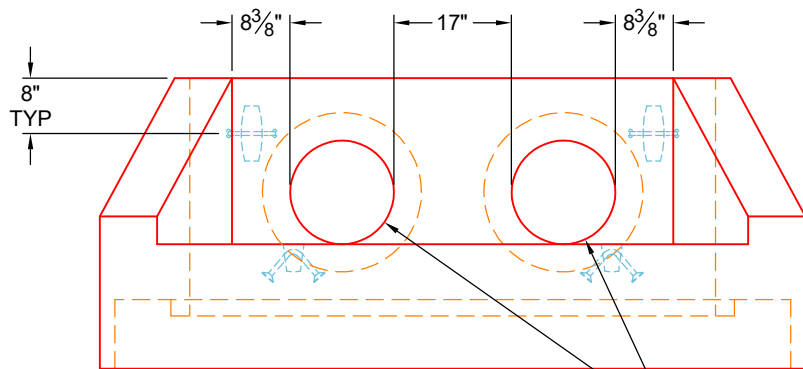

FRONT VIEW

2 EA. Ø23" OPENINGS STEPPED DOWN TO Ø15" OPENINGS FOR DOUBLE 15" RCP PIPES

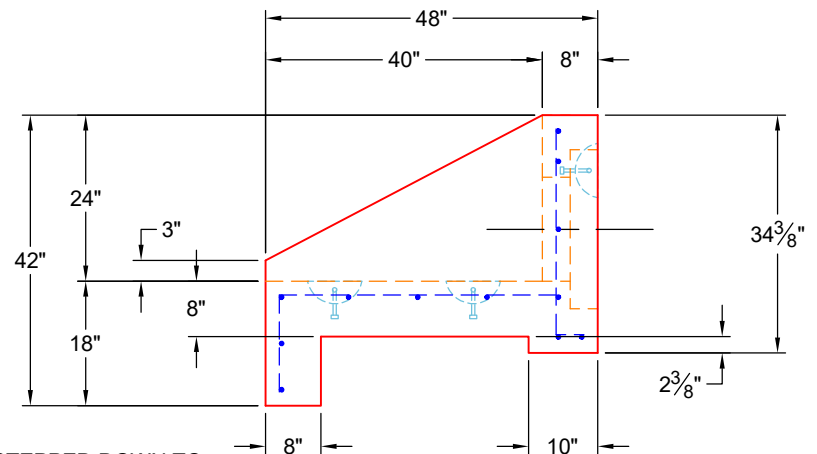

SIDE VIEW

PRODUCTION WORK ORDER

PRODUCT I.D.: HWDBLCUSTOM

DESCRIPTION: 15" DOUBLE SLOPED & FLARED HEADWALL



QUALITY CONTROL CHECKLIST

- ALL DIMENSIONS CORRECT.
- LIFTERS INSTALLED.
- OPENING CENTERED.
- REINFORCING CORRECT.
- SURFACE QUALITY ACCEPTABLE.
- EDGES CHAMFERED.
- ALL PATCHWORK ACCEPTABLE.

PRODUCT VIEW: RIGHT SIDE UP

CUSTOMER: WINWATER HARTFORD KY CO.

PLANT: BEAVER DAM, KY

PROJECT: WEIRS CREEK SUBDIVISION

WEIGHT: 5,525 LBS

STRUCTURE: 15IN DBL S&F HW 2

TOP SECTION JOINT: N / A

ORDER NO: 25-0232

BASE SECTION JOINT: N / A

PC: A. CHAMBERS

DRAWING: J. COPPAGE

QC CHECK INITIALS:

DATE: 10/15/25

SCALE: NTS

PG. 1 OF 4

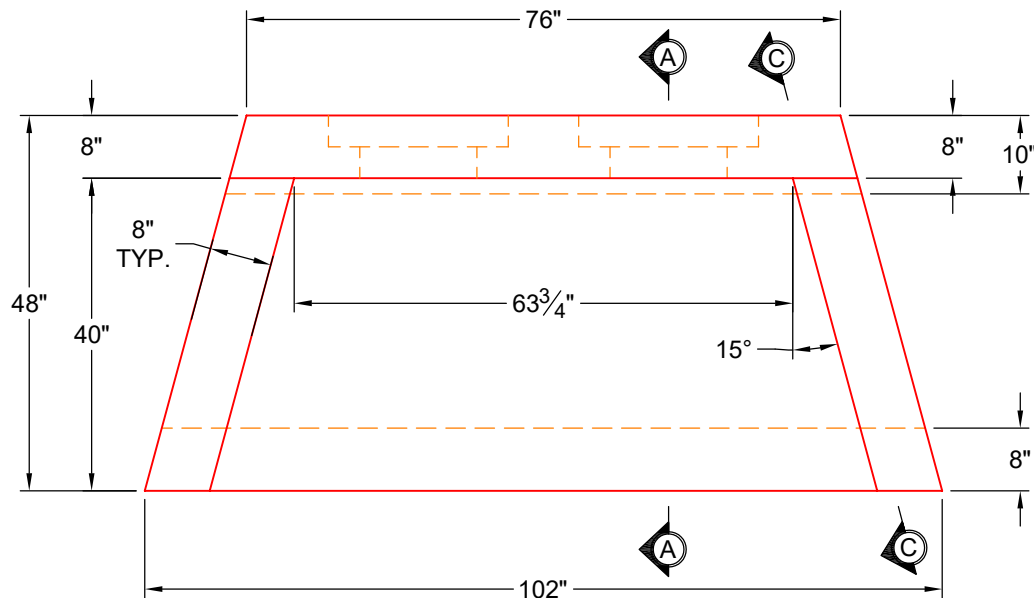

PLAN VIEW

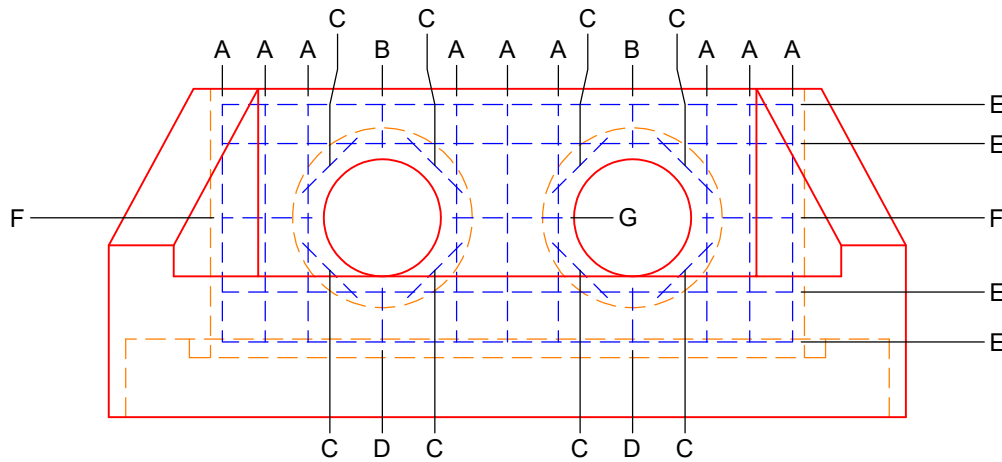

FRONT VIEW

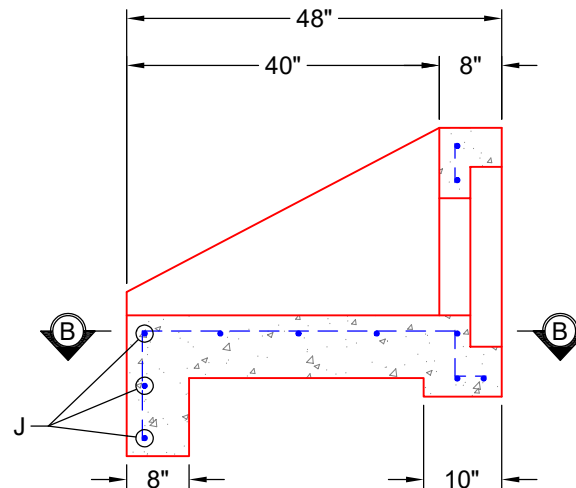

SECTION A-A

GENERAL NOTES:

1. PER ASTM C-913 (LATEST REVISION) SPECS
2. CONCRETE: 5,000 PSI AT 28 DAYS
3. REINFORCEMENT: SEE SHEETS 2, 3, & 4 FOR REBAR INFORMATION - MIN. 2" REBAR CLEARANCE (TYP)
4. TOTAL WEIGHT: 5,315 LBS
 - FIRST POUR: 3,665 LBS
 - SECOND POUR: 1,650 LBS

PRODUCTION WORK ORDER

PRODUCT I.D.: HWDBLCUSTOM

DESCRIPTION: 15" DOUBLE SLOPED & FLARED HEADWALL REBAR LAYOUT



QUALITY CONTROL CHECKLIST

- ALL DIMENSIONS CORRECT.
- LIFTERS INSTALLED.
- OPENING CENTERED.
- REINFORCING CORRECT.
- SURFACE QUALITY ACCEPTABLE.
- EDGES CHAMFERED.
- ALL PATCHWORK ACCEPTABLE.

PRODUCT VIEW: RIGHT SIDE UP

CUSTOMER: WINWATER HARTFORD

PLANT: BEAVER DAM, KY

PROJECT: WEIRS CREEK SUBDIVISION

WEIGHT: 5,525 LBS

STRUCTURE: 15IN DBL S&F HW 2

TOP SECTION JOINT: N / A

ORDER NO: 25-0232

BASE SECTION JOINT: N / A

PC: A. CHAMBERS

DRAWING: J. COPPAGE

QC CHECK INITIALS:

DATE: 10/15/25

SCALE: NTS

PG. 2 OF 4

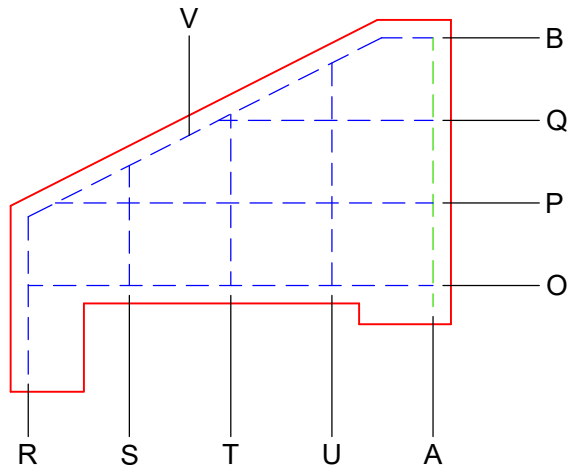

SECTION C-C

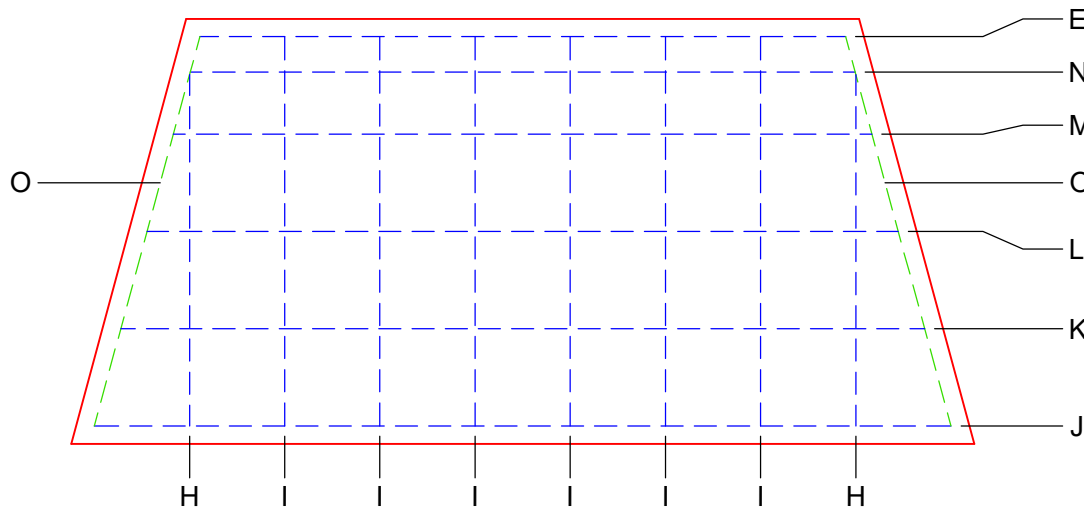

SECTION B-B

GENERAL NOTES:

1. PER ASTM C-913 (LATEST REVISION) SPECS
2. CONCRETE: 5,000 PSI AT 28 DAYS
3. REINFORCEMENT: SEE SHEETS 2, 3, & 4 FOR REBAR INFORMATION - MIN. 2" REBAR CLEARANCE (TYP)
4. TOTAL WEIGHT: 5,315 LBS
 - FIRST POUR: 3,665 LBS
 - SECOND POUR: 1,650 LBS

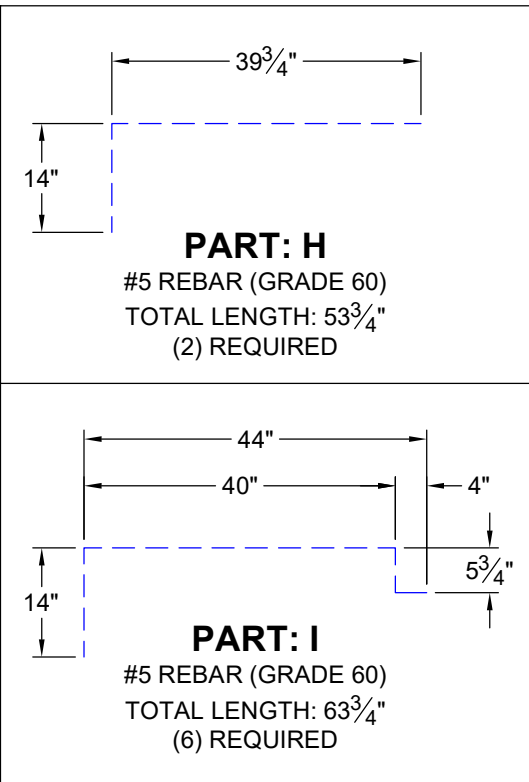

PART: H

#5 REBAR (GRADE 60)
 TOTAL LENGTH: 53³/₄"
 (2) REQUIRED

PART: I

#5 REBAR (GRADE 60)
 TOTAL LENGTH: 63³/₄"
 (6) REQUIRED

PRODUCTION WORK ORDER

PRODUCT I.D.: HWDBLCUSTOM

DESCRIPTION: 15" DOUBLE SLOPED & FLARED HEADWALL REBAR LAYOUT



QUALITY CONTROL CHECKLIST

- ALL DIMENSIONS CORRECT.
- LIFTERS INSTALLED.
- OPENING CENTERED.
- REINFORCING CORRECT.
- SURFACE QUALITY ACCEPTABLE.
- EDGES CHAMFERED.
- ALL PATCHWORK ACCEPTABLE.

PRODUCT VIEW: RIGHT SIDE UP

CUSTOMER: WINWATER HARTFORD KY CO.

PLANT: BEAVER DAM, KY

PROJECT: WEIRS CREEK SUBDIVISION

WEIGHT: 5,525 LBS

STRUCTURE: 15IN DBL S&F HW 2

TOP SECTION JOINT: N / A

ORDER NO: 25-0232

BASE SECTION JOINT: N / A

PC: A. CHAMBERS

DRAWING: J. COPPAGE

QC CHECK INITIALS:

DATE: 10/15/25

SCALE: NTS

PG. 3 OF 4

ITEM	LENGTH	SIZE	QTY.
A	31"	#5	9
B	6"	#5	4
C	10"	#5	8
D	7"	#5	2
E	73"	#5	5
F	12"	#5	2
G	14"	#5	1
H	SEE DETAIL	#5	2
I	SEE DETAIL	#5	6
J	97"	#5	3
K	91"	#5	1

ITEM	LENGTH	SIZE	QTY.
L	85"	#5	1
M	79"	#5	1
N	75"	#5	1
O	46"	#5	2
P	43"	#5	2
Q	25"	#5	2
R	18"	#5	2
S	14"	#5	2
T	20"	#5	2
U	26"	#5	2
V	45"	#5	2

PRODUCTION WORK ORDER		PRODUCT I.D.: HWDBLCUSTOM	DESCRIPTION: 15" DOUBLE SLOPED & FLARED HEADWALL REBAR CUTSHEET		
	QUALITY CONTROL CHECKLIST <input type="checkbox"/> ALL DIMENSIONS CORRECT. <input type="checkbox"/> LIFTERS INSTALLED. <input type="checkbox"/> OPENING CENTERED. <input type="checkbox"/> REINFORCING CORRECT. <input type="checkbox"/> SURFACE QUALITY ACCEPTABLE. <input type="checkbox"/> EDGES CHAMFERED. <input type="checkbox"/> ALL PATCHWORK ACCEPTABLE.	PRODUCT VIEW: RIGHT SIDE UP	CUSTOMER: WINWATER HARTFORD KY CO.		
		PLANT: BEAVER DAM, KY	PROJECT: WEIRS CREEK SUBDIVISION		
		WEIGHT: 5,525 LBS	STRUCTURE: 15IN DBL S&F HW 2		
		TOP SECTION JOINT: N / A	ORDER NO: 25-0232		
		BASE SECTION JOINT: N / A	PC: A. CHAMBERS	DRAWING: J. COPPAGE	
		QC CHECK INITIALS:	DATE: 10/15/25	SCALE: NTS	PG. 4 OF 4