

Job Name: 25-0230 - Casey's General Store 4606
 Job Location: Morgantown, KY
 Contractor: American Contracting LLC

Plant: 100

1/7/2026 8:32:49 AM

Tech: J. Horsley

PC: A. Chambers



Structure ID: MH 9

P1 MH048BAVF

MH BASE Custom Ht T/n

- P3) 24" - CASTING HEIGHT - 8"
- P2) 48" - ECC CONE w/ 24" HOLE F/G - 24"
- P1) 48" - MH BASE Custom Ht T/n - 69"
- 1) CASTING - HOE KY-510 F/C (KY TY.2)
- 1) 48" - Conseal CS-102 1.00"
- 1) Hole - 30
- 1) Hole - 20
- 1) Hole - 16
- 6) MH Step ML-10-TDS-NCR - 10"

0 lb
 1550 lb
 5613 lb
 510 lb
 0 lb
 0 lb
 0 lb
 0 lb
 0 lb
 0 lb
 Structure Total: 7673 lb

- Structure Notes:**
1. PER KYTC MANHOLE TYPE B / ASTM C-478 SPECIFICATIONS
 2. CONCRETE: 4,000 PSI AT 28 DAYS
 3. REINFORCEMENT: PER ASTM A615
 3. NO STORM INVERT
 4. STEPS AT 180 DEGREES
 5. CASTING BY ICAST (HOE KY-510 FRAME & COVER)

Rim: 422.1' Rim to Invert: 6.43' Slack: 0.16" Sump: 24" Step Position: 180°

Position	Elev	Angle	Ext. (cw)	Pipe	Pipe OD	Connector	Hole	Horz Size	Up ()	Offset
Invert 1	415.67'	270°	136.659"	24" HDPE	27.8"	Hole 30	30"	32.406"	22.1"	0"
Invert 2	417.45'	0°	0"	15" HDPE	17.6"	Hole 20	20"	20.629"	44.06"	0"
Invert 3	417.74'	90°	45.553"	12" HDPE	14.5"	Hole 16	16"	16.312"	47.59"	0"
Invert 4										
Invert 5										
Invert 6										
Invert 7										
Invert 8										

RIGHT-SIDE UP VIEW (int. dimensions)

UPSIDE-DOWN VIEW (int. dimensions)

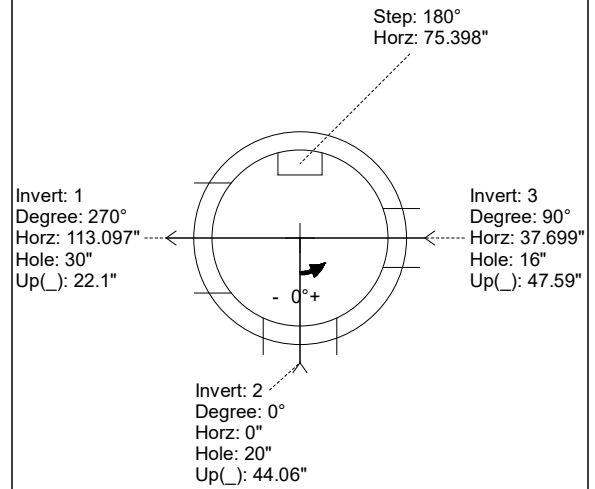
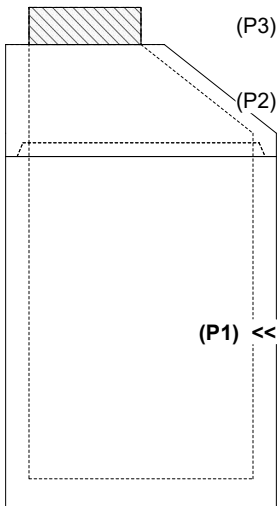

INSIDE WALL DIMENSIONS

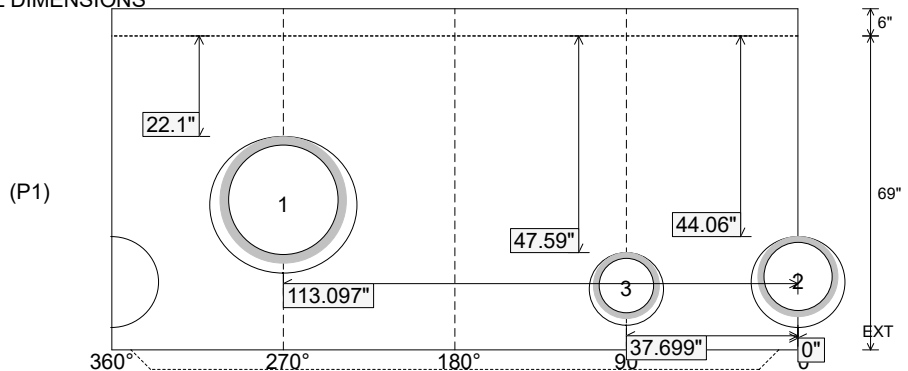

Coating (Int):
 Coating (Ext):

Seam Up: Tongue
 Seam Dn: n/a

Wall Thickness: 5"
 Floor Height: 6"

Height (Int): 69"
 Height (Ext): 75"

Weight (Net): 5613 lb
 Volume (Net): 1.43cu.yd