

**Structure ID: MH 5**

**P1 MH048BA24**

**MH BASE T/n**

P3) 24" - CASTING HEIGHT - 8" P2) 48" - ECC CONE w/ 24" HOLE F/G - 24" P1) 48" - MH BASE T/n - 24" 1) CASTING - HOE KY-510 F/C (KY TY.2) 1) 48" - DBL 1"x14.5' Butyl (2x) 2) Hole - 16 4) MH Step ML-10-TDS-NCR - 10"	0 lb 1550 lb 2835 lb 510 lb 0 lb 0 lb 0 lb ----- 4895 lb	<b>Structure Notes:</b> 1. KYTC DBI TYPE 11 / ASTM C-913 SPEC'S. 2. CONCRETE = 4,000 PSI AT 28 DAYS. 3. NO INVERT CHANNEL. 4. CASTING BY ICAST (HOE KY-510 F/C)  REINFORCING PER ASTM A615 (GRADE 60). - TOP SLAB = H2O LOADING. - RISER/WALLS (As .12) - FLOOR (As .31) #5 BARS AT 12" C.C.E.W.
---	--	---

Structure Total: 4895 lb

Rim: 423.76'    Rim to Invert: 4.67'    Slack: 0.04"    Sump: 0"    Step Position: 252.5°

Position	Elev	Angle	Ext. (cw)	Pipe	Pipe OD	Connector	Hole	Horz Size	Up ( )	Offset
Invert 1	419.09'	0°	0"	12" HDPE	14.5"	Hole 16	16"	16.312"	-1.25"	0"
Invert 2	419.09'	145°	73.375"	12" HDPE	14.5"	Hole 16	16"	16.312"	-1.25"	0"
Invert 3										
Invert 4										
Invert 5										
Invert 6										
Invert 7										
Invert 8										

**RIGHT-SIDE UP VIEW (int. dimensions)**

**UPSIDE-DOWN VIEW (int. dimensions)**

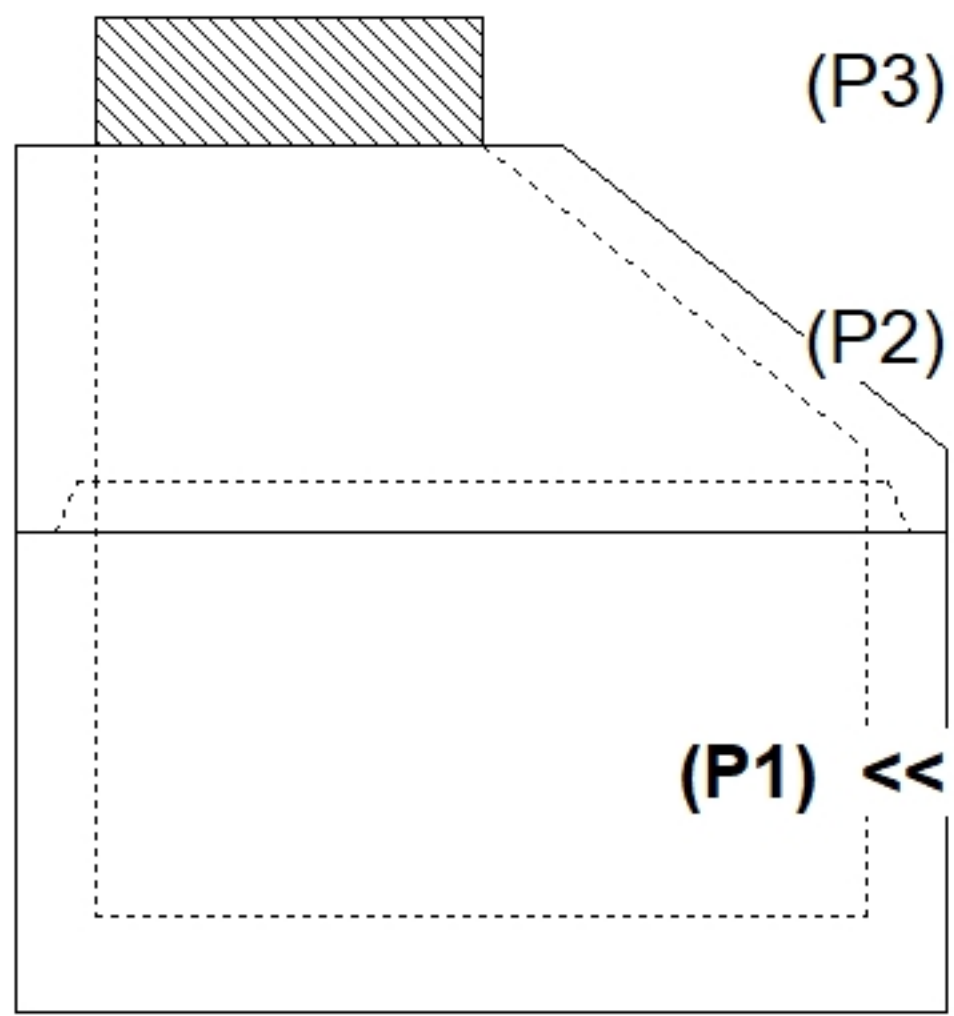
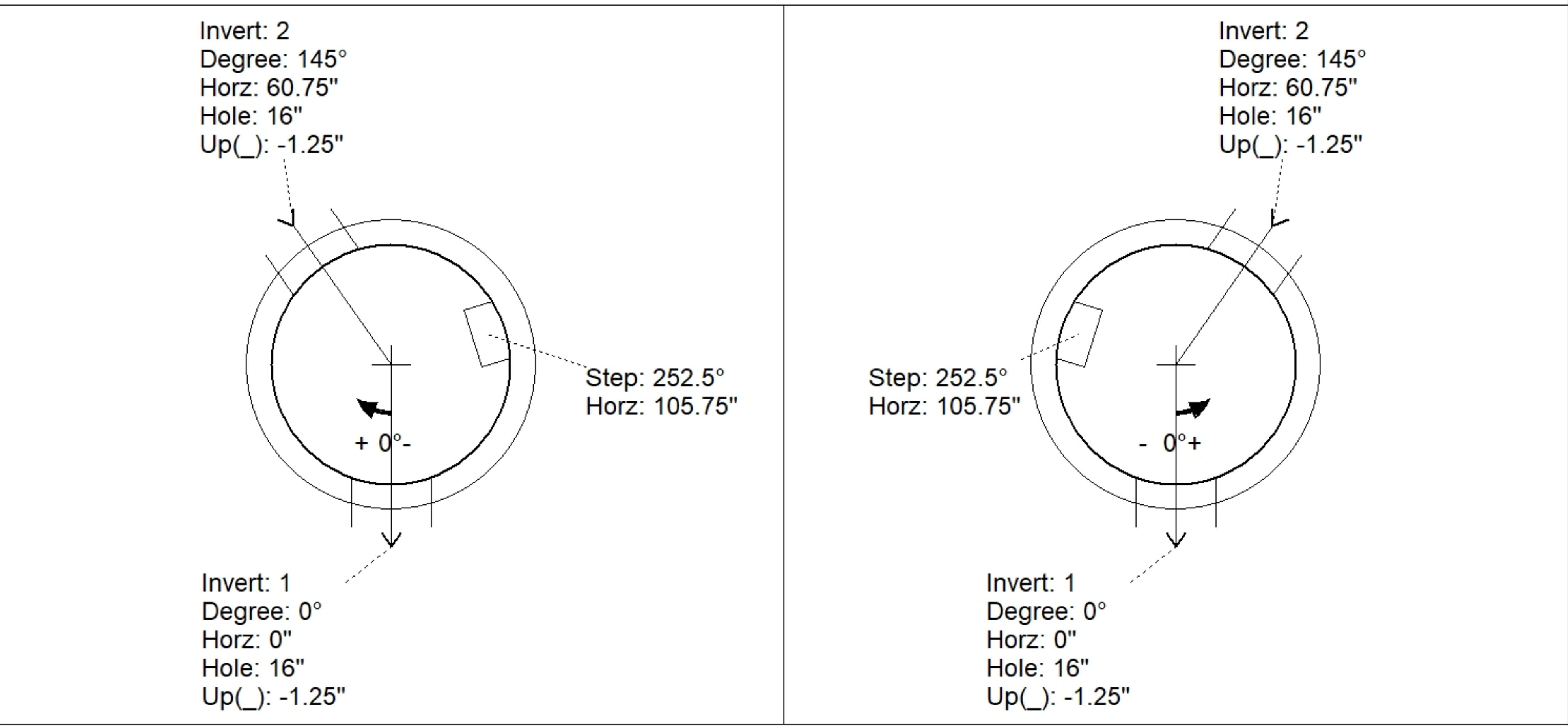

**INSIDE WALL DIMENSIONS**

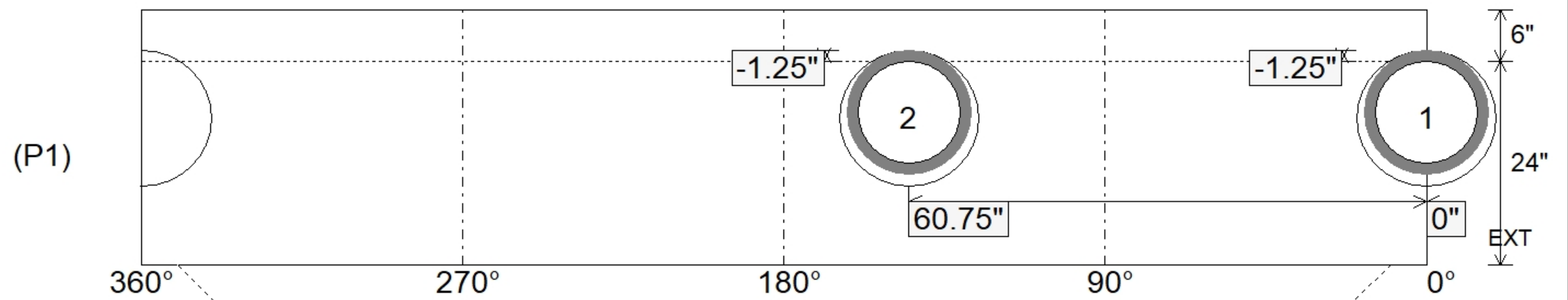

Coating (Int): Coating (Ext):	Seam Up: Tongue Seam Dn: n/a	Wall Thickness: 5" Floor Height: 6"	Height (Int): 24" Height (Ext): 30"	Weight (Net): 2835 lb Volume (Net): 0.72cu.yd
----------------------------------	---------------------------------	--	--	--