

Job Name: 25-0226 MS 161kv SWITCHING STATION	Plant: 100	Tech: J. Horsley - F
Job Location: Columbus, MS	11/3/2025 5:02:28 PM	PC: A. Chambers
Contractor: TVA		

Structure ID: CB 1

P1 MH048BAVF

MH BASE Custom Ht T/n

P4) 24" - CASTING HEIGHT - 2"	0 lb
P3) 24" - GRADE RING F/F - 6"	405 lb
P2) 48" - MH FLAT TOP w/ 24" Center Hole F/G - 12"	1700 lb
P1) 48" - MH BASE Custom Ht T/n - 37"	3599 lb
1) CASTING - EJ 6488 Beehive Grate	250 lb
1) 48" - Conseal CS-102 1.00"	0 lb
1) Hole - 30	0 lb
Structure Total:	5954 lb

Structure Notes:
 1. PER ASTM C478 SPECIFICATIONS.
 2. CONCRETE = 4,000 PSI AT 28 DAYS.
 3. NO STEPS AND NO INVERT CHANNEL.
 4. CASTING BY I-CAST (EJ 6488 BEEHIVE GRATE).

 REINFORCING PER ASTM A615 (GRADE 60).
 - TOP SLAB H20 LOADING.
 - RISER/WALLS (As .12)
 - FLOOR (As .31) #5 BARS AT 12" C.C.E.W.

Rim: 351.15' Rim to Invert: 4.65' Slack: 0.7" Sump: 1.9" Step Position:

Position	Elev	Angle	Ext. (cw)	Pipe	Pipe OD	Connector	Hole	Horz Size	Up ()	Offset
Invert 1	346.5'	0°	0"	24" HDPE	27.8"	Hole 30	30"	32.406"	0"	0"
Invert 2										
Invert 3										
Invert 4										
Invert 5										
Invert 6										
Invert 7										
Invert 8										

RIGHT-SIDE UP VIEW (int. dimensions)

UPSIDE-DOWN VIEW (int. dimensions)

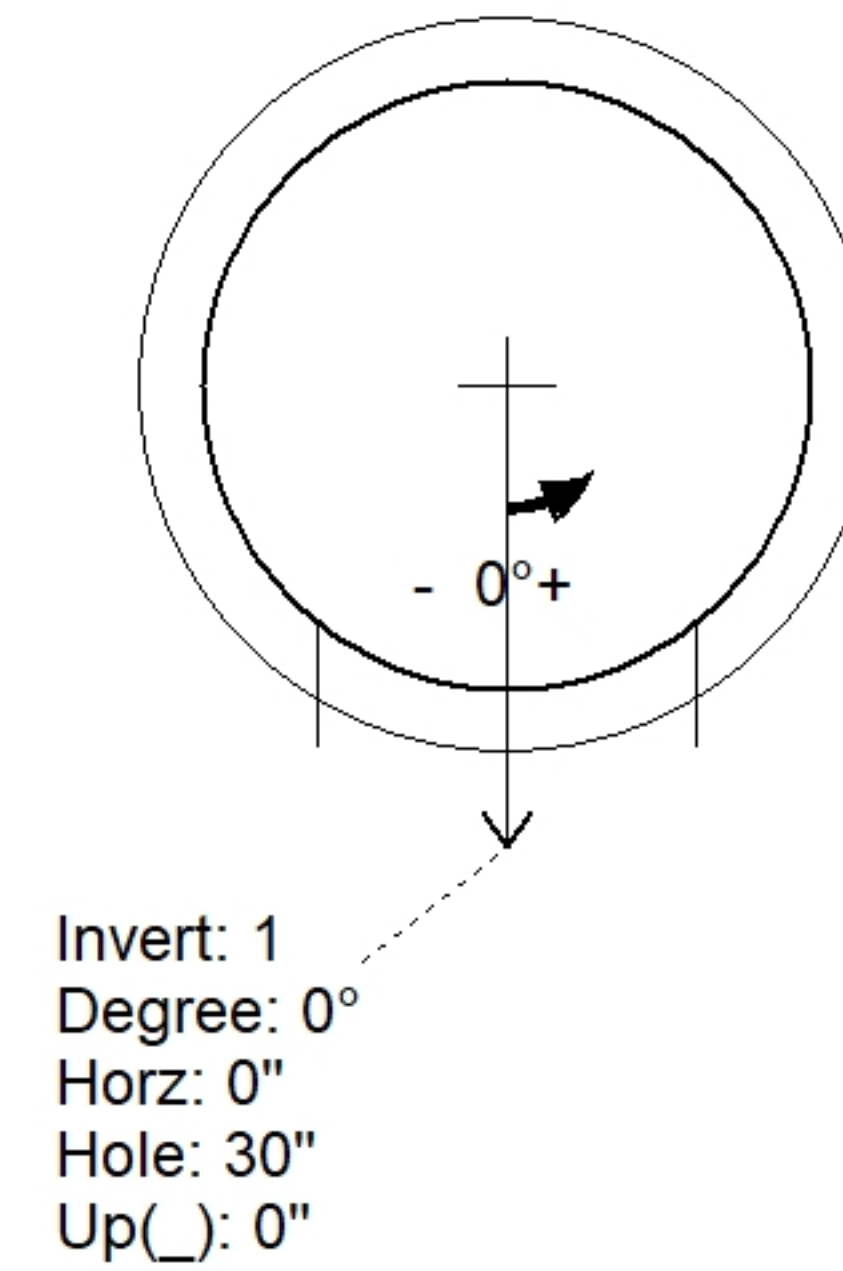
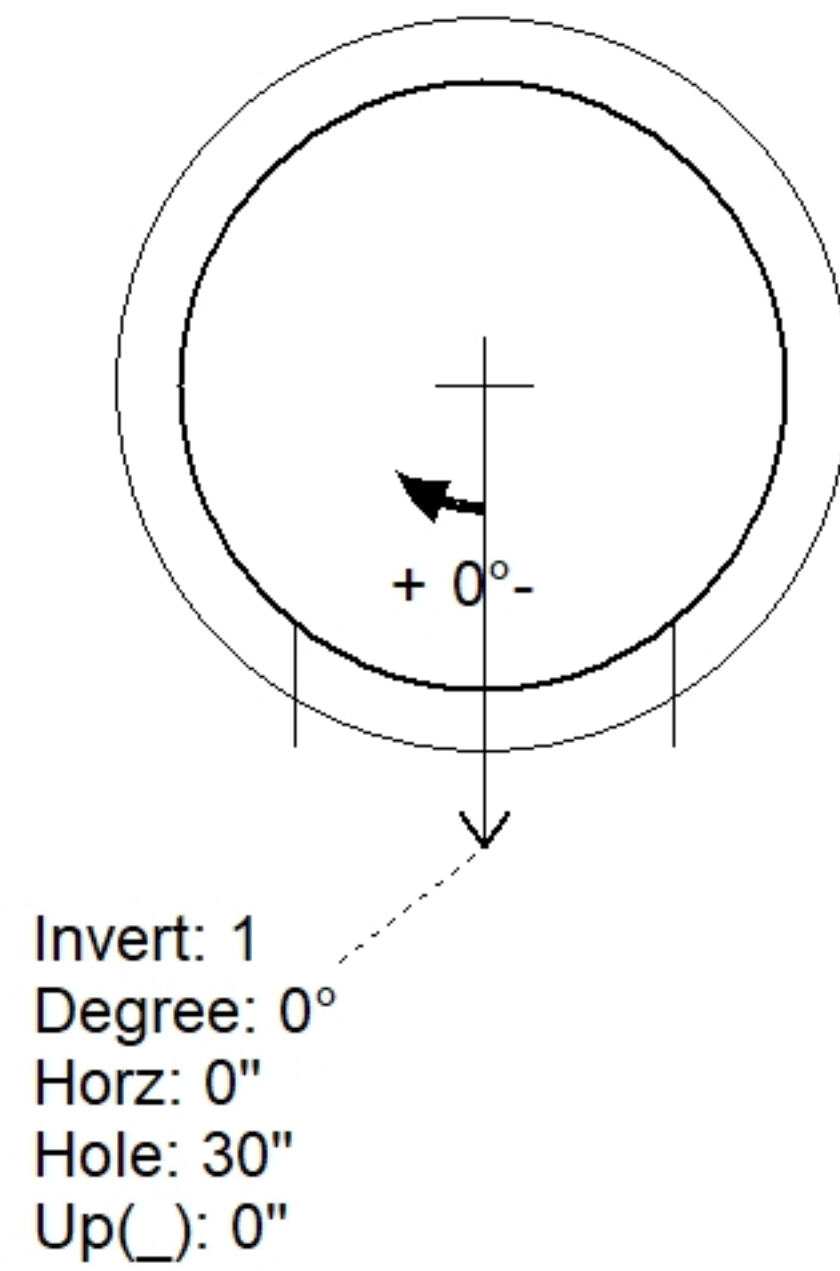
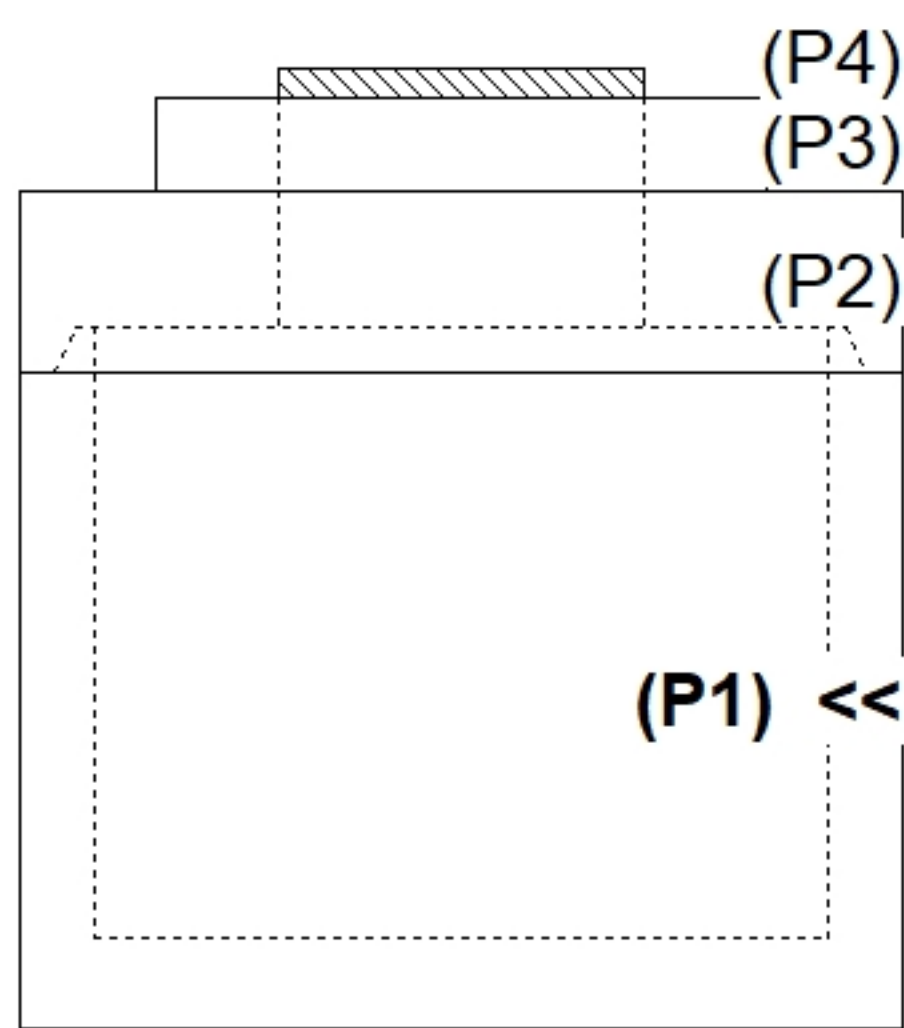

INSIDE WALL DIMENSIONS

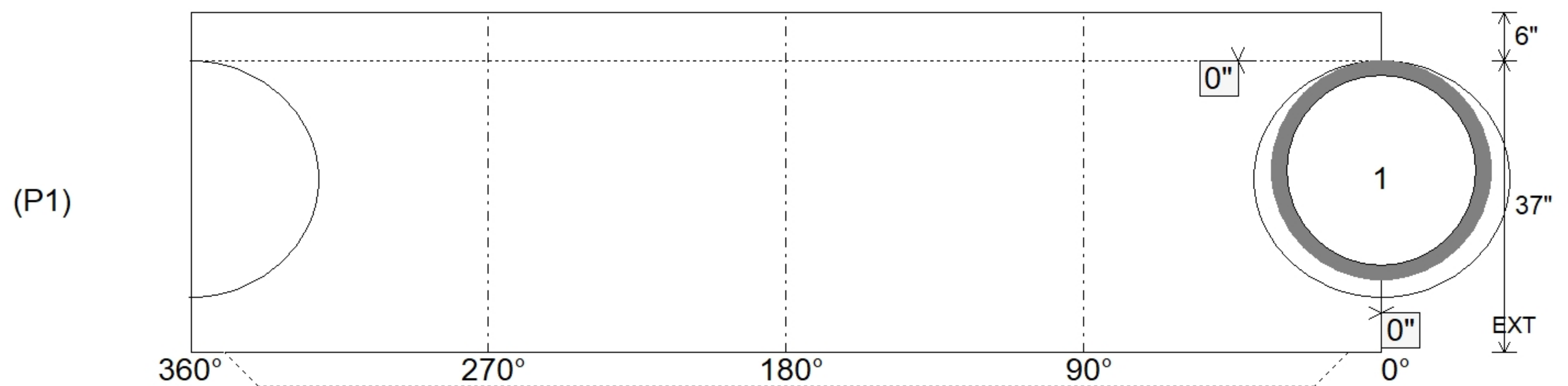

Coating (Int):	Seam Up: Tongue	Wall Thickness: 5"	Height (Int): 37"	Weight (Net): 3599 lb
Coating (Ext):	Seam Dn: n/a	Floor Height: 6"	Height (Ext): 43"	Volume (Net): 0.92cu.yd