

Job Name: 25-0210 Salsa Square Development	Plant: 100	Tech: J. Horsley - A	
Job Location: Bowling Green, KY Contractor: Scott & Ritter, Inc.	12/1/2025 4:00:54 PM	PC: Celina Goff	

Structure ID: C1

P3 MH048RS48

MH RISER T/G

P6) 24" - CASTING HEIGHT - 7"	0 lb
P5) 48" - MH FLAT TOP w/ 24" ECC Hole F/G - 12"	1561 lb
P4) 48" - MH RISER T/G - 48"	3353 lb
P3) 48" - MH RISER T/G - 48"	3353 lb
P2) 48" - MH RISER Custom Ht T/F - 53"	3567 lb
P1) 48" - P.I.P. BY OTHERS - BTM SLAB F/n - 0"	0 lb
1) CASTING - HOE MC-315 F/C Storm	258 lb
1) Hole - 20	0 lb
Structure Total:	12093 lb

Structure Notes:
 1. PER ASTM C478 SPECIFICATIONS.
 2. CONCRETE = 4,000 PSI AT 28 DAYS.
 3. CASTING BY ICAST (HOE MC-315 F/C).

 REINFORCING PER ASTM A615 (GRADE 60).
 - TOP SLAB (As .62) #5 BARS AT 6" C.C.E.W.
 - RISER (As .12)

Rim: 529' Rim to Invert: 13' Slack: 0" Sump: 12" Step Position:

Position	Elev	Angle	Ext. (cw)	Pipe	Pipe OD	Connector	Hole	Horz Size	Up (L)	Offset
Invert 1										
Invert 2										
Invert 3										
Invert 4										
Invert 5										
Invert 6										
Invert 7										
Invert 8										

RIGHT-SIDE UP VIEW (int. dimensions)

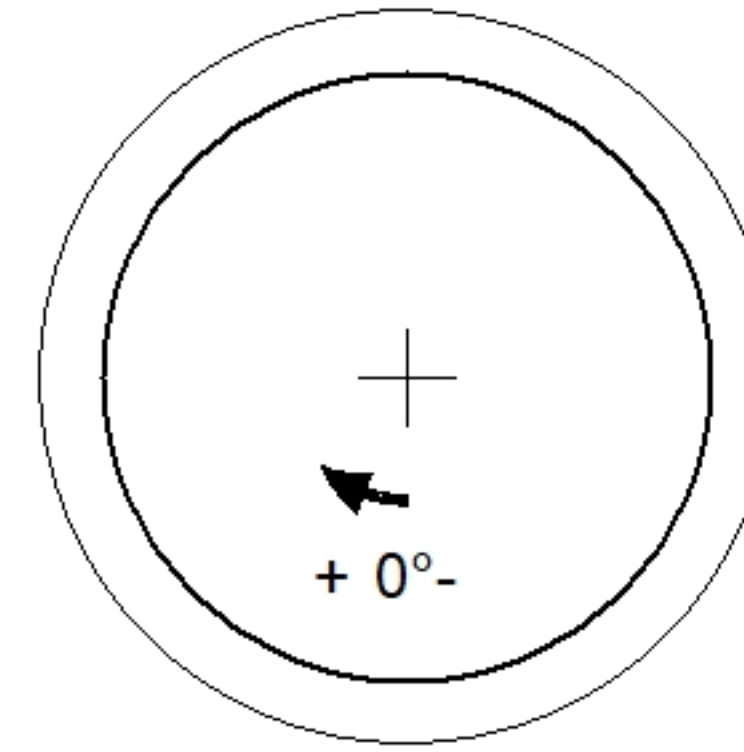
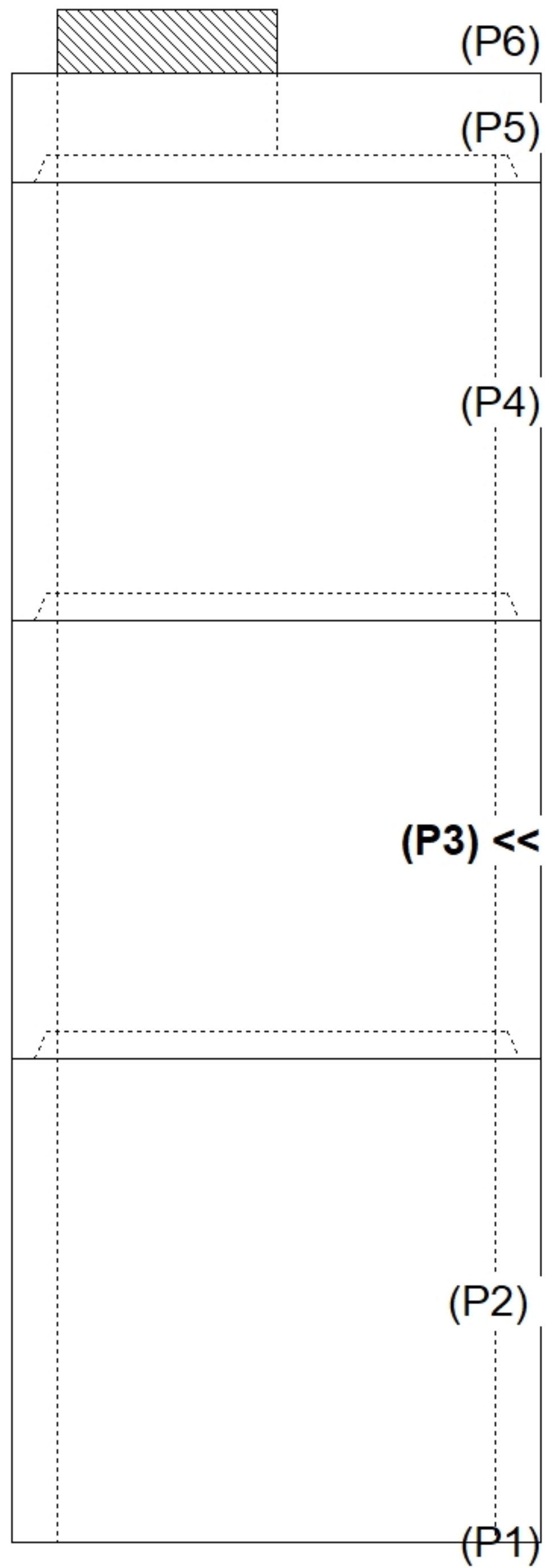

INSIDE WALL DIMENSIONS

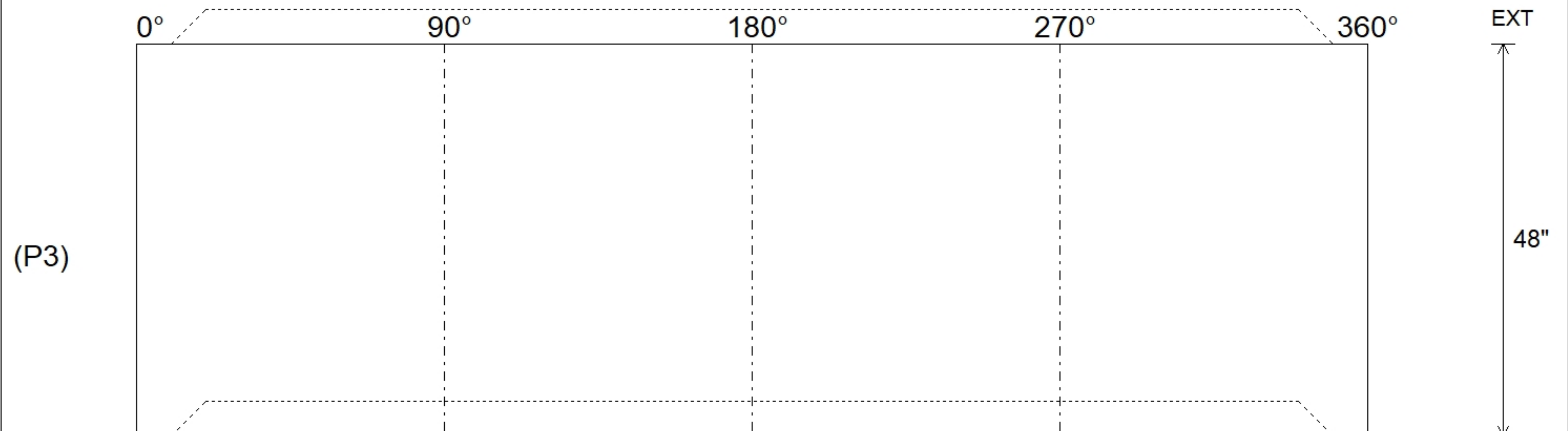

Coating (Int):	Seam Up: Tongue	Wall Thickness: 5"	Height (Int): 48"	Weight (Net): 3353 lb
Coating (Ext):	Seam Dn: Groove	Floor Height: 0"	Height (Ext): 48"	Volume (Net): 0.86cu.yd