

Structure ID: A5

P1 MH048BA48

MH BASE T/n

P4) 30" x 30" - CASTING HEIGHT - 4" P3) 48" - MH FLAT TOP w/30"x30" Hole F/G - 12" P2) 48" - MH RISER Custom Ht T/G - 52" P1) 48" - MH BASE T/n - 48" 1) CASTING - HOE 468 F/G 2) 48" - Conseal CS-102 1.00" 1) 30" x 30" - Conseal CS-102 1.00" 1) Hole - 30 1) Hole - 24 1) Hole - 12 8) MH Step ML-10-TDS-NCR - 10"	0 lb 1350 lb 3585 lb 4170 lb 489 lb 0 lb 0 lb 0 lb 0 lb 0 lb 0 lb ----- Structure Total: 9594 lb
--	--

Structure Notes:
 PLAN LABEL: ST-A5
 1. HOE 468 F/G PROVIDED BY ICAST.
 2. PER ASTM C478 SPECIFICATIONS.
 3. CONCRETE = 4,000 PSI AT 28 DAYS.
 4. REINFORCING PER ASTM A615 (GRADE 60).
 - TOP SLAB (As .62) #5 BARS AT 6" C.C.E.W..
 - RISER/WALLS (As .12)
 - FLOOR (As .31) #5 BARS AT 12" C.C.E.W.
 5. PLEASE VERIFY THE REQUIRED I.E. OF THE 8" HDPE DOWNSPOUT PIPE. ASSUMED AS 529.00 IN THESE SUBMITTALS (5' BELOW WAREHOUSE SLAB FFE).

Rim: 533.15' Rim to Invert: 9.53' Slack: 0.26" Sump: 1.9" Step Position: 0°

Position	Elev	Angle	Ext. (cw)	Pipe	Pipe OD	Connector	Hole	Horz Size	Up ()	Offset
Invert 1	523.62'	0°	0"	24" HDPE	27.8"	Hole 30	30"	32.406"	0"	0"
Invert 2	523.62'	180°	91.125"	18" HDPE	21.2"	Hole 24	24"	25.133"	0.25"	0"
Invert 3										
Invert 4										
Invert 5										
Invert 6										
Invert 7										
Invert 8										

RIGHT-SIDE UP VIEW (int. dimensions)

UPSIDE-DOWN VIEW (int. dimensions)

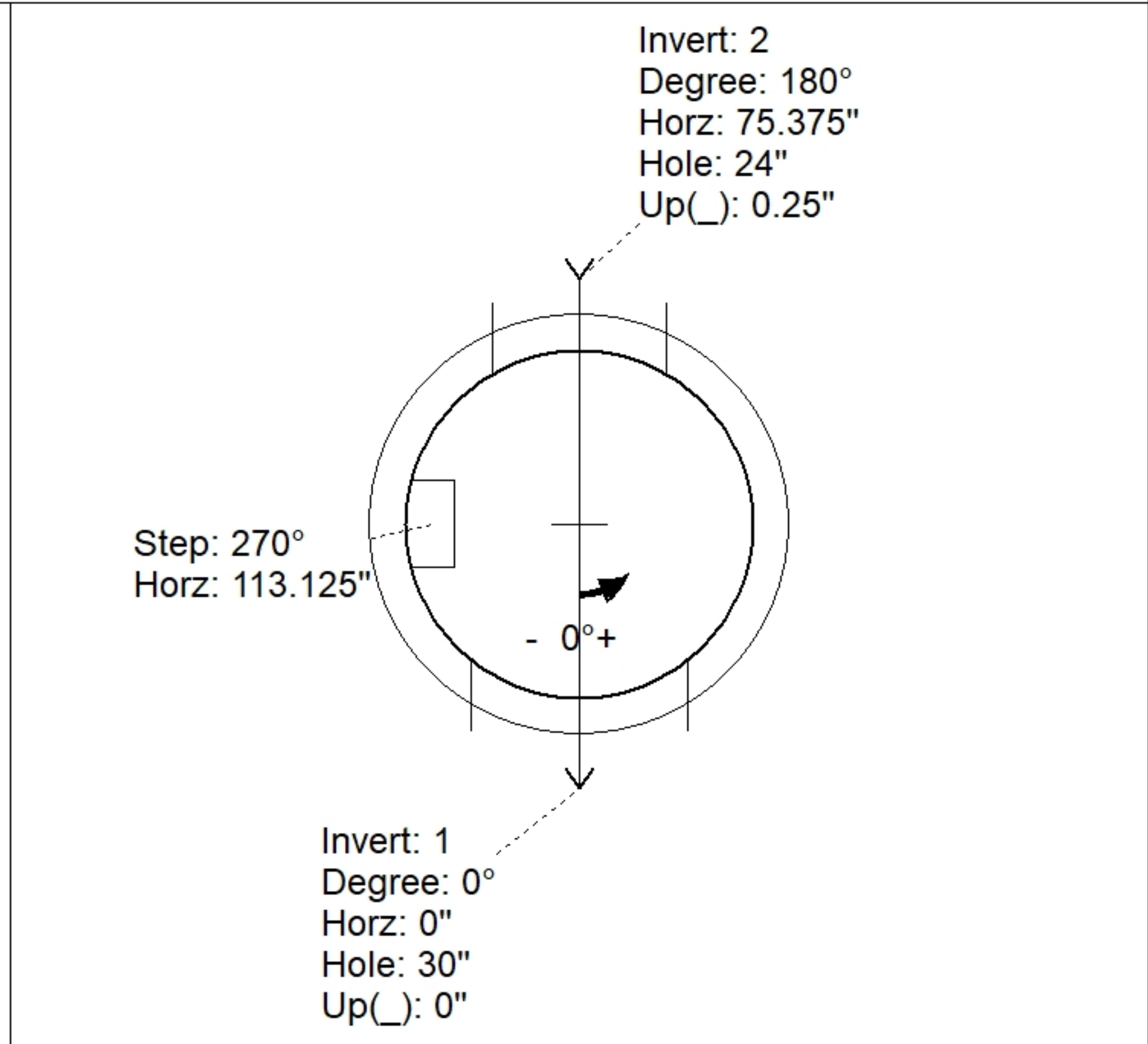
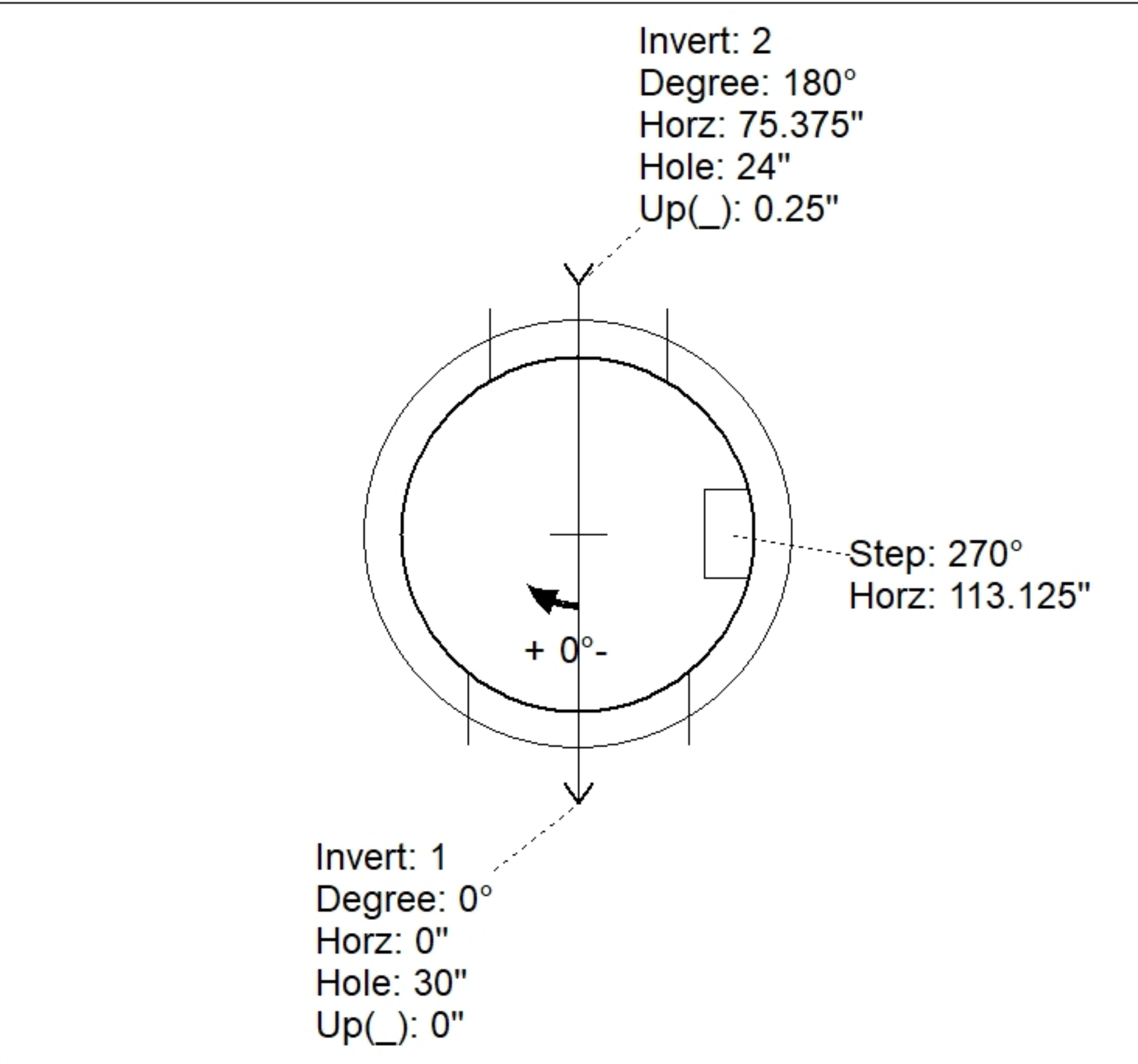
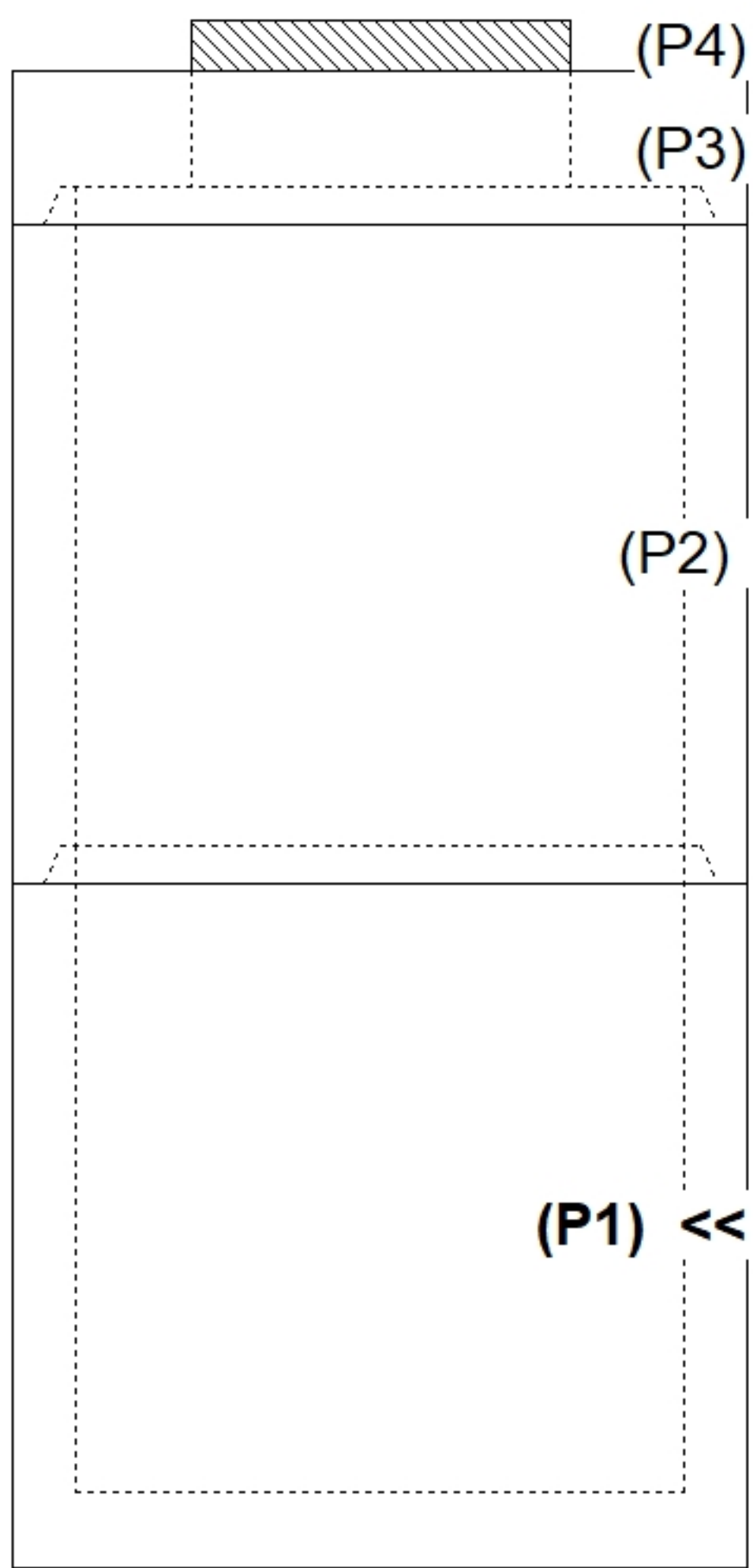

INSIDE WALL DIMENSIONS

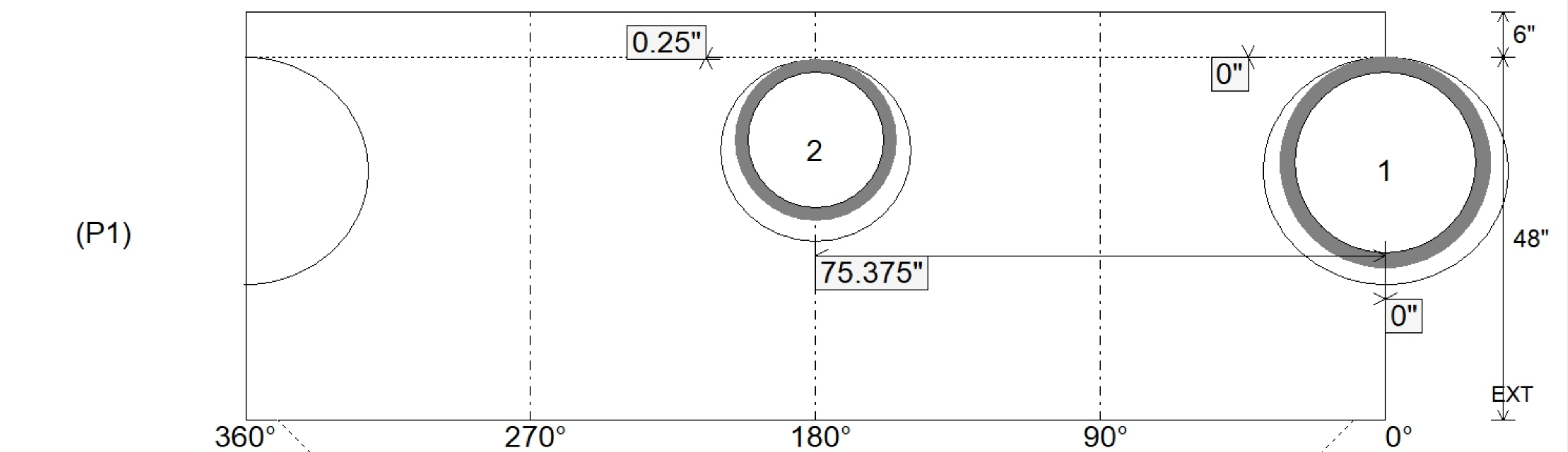

Coating (Int): Coating (Ext):	Seam Up: Tongue Seam Dn: n/a	Wall Thickness: 5" Floor Height: 6"	Height (Int): 48" Height (Ext): 54"	Weight (Net): 4170 lb Volume (Net): 1.06cu.yd
----------------------------------	---------------------------------	--	--	--