

Job Name: 25-0209 Garrison Gardens
 Job Location: Bowling Green, KY
 Contractor: Scotty's Contracting & Stone, LLC

Plant: 100
 1/23/2026 4:32:15 PM

Tech: J. Horsley - A
 PC: Celina Goff



Structure ID: CB 5-2

P1 MH048BA24

MH BASE T/n

- P3) 30" x 30" - CASTING HEIGHT - 4"
- P2) 48" - MH FLAT TOP w/30"x30" Hole F/G - 12"
- P1) 48" - MH BASE T/n - 24"
- 1) CASTING - HOE 468 F/G
- 1) 48" - Conseal CS-102 1.00"
- 1) 30" x 30" - Conseal CS-102 1.00"
- 1) Hole - 20
- 1) Hole - 6

0 lb
 1350 lb
 2860 lb
 489 lb
 0 lb
 0 lb
 0 lb
 0 lb
 0 lb
 Structure Total: 4699 lb

- Structure Notes:**
1. PER ASTM C-478 SPECIFICATIONS
 2. CONCRETE: 4,000 PSI AT 28 DAYS
 3. REINFORCEMENT: PER ASTM A615
 4. NO STORM INVERT
 5. NO STEPS
 6. HOE 468 FRAME & GRATE SUPPLIED BY ICAST

Rim: 521.32' Rim to Invert: 3.41' Slack: 0.92" Sump: 0" Step Position:

Position	Elev	Angle	Ext. (cw)	Pipe	Pipe OD	Connector	Hole	Horz Size	Up ()	Offset
Invert 1	517.91'	0°	0"	15" HDPE	17.6"	Hole 20	20"	20.629"	-1.3"	0"
Invert 2	518.9'	155°	78.453"	4" HDPE (perf pipe)	4.8"	Hole 6	6"	6.016"	11.48"	0"
Invert 3										
Invert 4										
Invert 5										
Invert 6										
Invert 7										
Invert 8										

RIGHT-SIDE UP VIEW (int. dimensions)

UPSIDE-DOWN VIEW (int. dimensions)

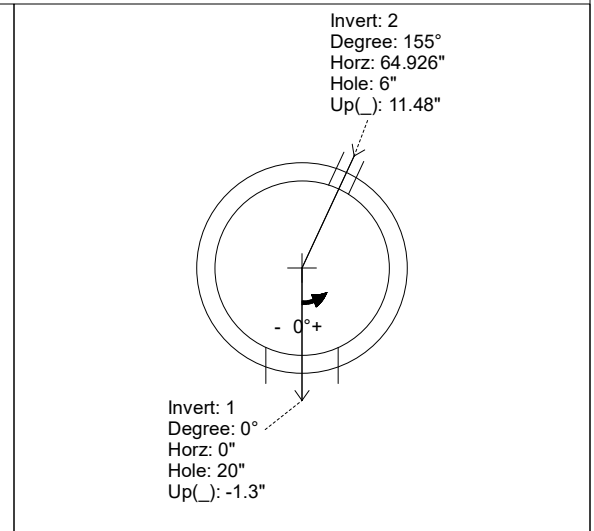
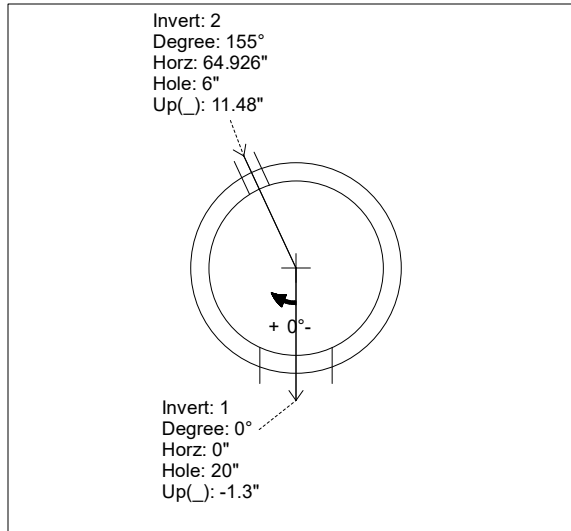
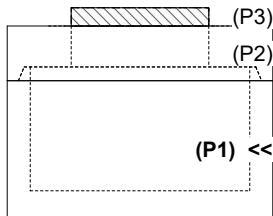

INSIDE WALL DIMENSIONS

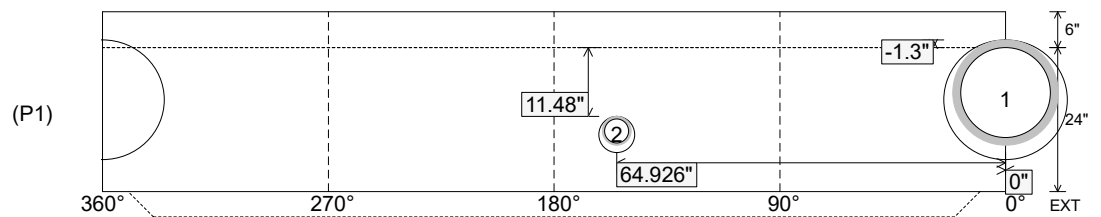

Coating (Int):
 Coating (Ext):

Seam Up: Tongue
 Seam Dn: n/a

Wall Thickness: 5"
 Floor Height: 6"

Height (Int): 24"
 Height (Ext): 30"

Weight (Net): 2860 lb
 Volume (Net): 0.73cu.yd