

Job Name: 25-0209 Garrison Gardens	Plant: 100	Tech: J. Horsley - A	
Job Location: Bowling Green, KY	1/23/2026 4:35:49 PM	PC: Celina Goff	
Contractor: Scotty's Contracting & Stone, LLC			

Structure ID: CB 3-7

P2 MH048RSVF

MH RISER Custom Ht T/G

P4) 30" x 30" - CASTING HEIGHT - 4"	0 lb
P3) 48" - MH FLAT TOP w/30"x30" Hole F/G - 12"	1350 lb
P2) 48" - MH RISER Custom Ht T/G - 50"	3165 lb
P1) 48" - MH BASE T/n - 42"	3948 lb
1) CASTING - HOE 468 F/G	489 lb
2) 48" - Conseal CS-102 1.00"	0 lb
1) 30" x 30" - Conseal CS-102 1.00"	0 lb
2) Hole - 30	0 lb
1) Hole - 6	0 lb
7) MH Step ML-10-TDS-NCR - 10"	0 lb
Structure Total:	8952 lb

Structure Notes:

- PER ASTM C-478 SPECIFICATIONS
- CONCRETE: 4,000 PSI AT 28 DAYS
- REINFORCEMENT: PER ASTM A615
- STEPS AT 270 DEGREES
- HOE 468 FRAME & GRATE SUPPLIED BY ICAST

Rim: 518.33' Rim to Invert: 8.9' Slack: 0.7' Sump: 1.9' Step Position: 270°

Position	Elev	Angle	Ext. (cw)	Pipe	Pipe OD	Connector	Hole	Horz Size	Up ()	Offset
Invert 1										
Invert 2	514.02'	180°	91.106"	24" HDPE	27.8"	Hole 30	30"	32.406"	8.83"	0"
Invert 3	516.12'	90°	45.553"	4" HDPE (perf pipe)	4.8"	Hole 6	6"	6.016"	35.53"	0"
Invert 4										
Invert 5										
Invert 6										
Invert 7										
Invert 8										

RIGHT-SIDE UP VIEW (int. dimensions)

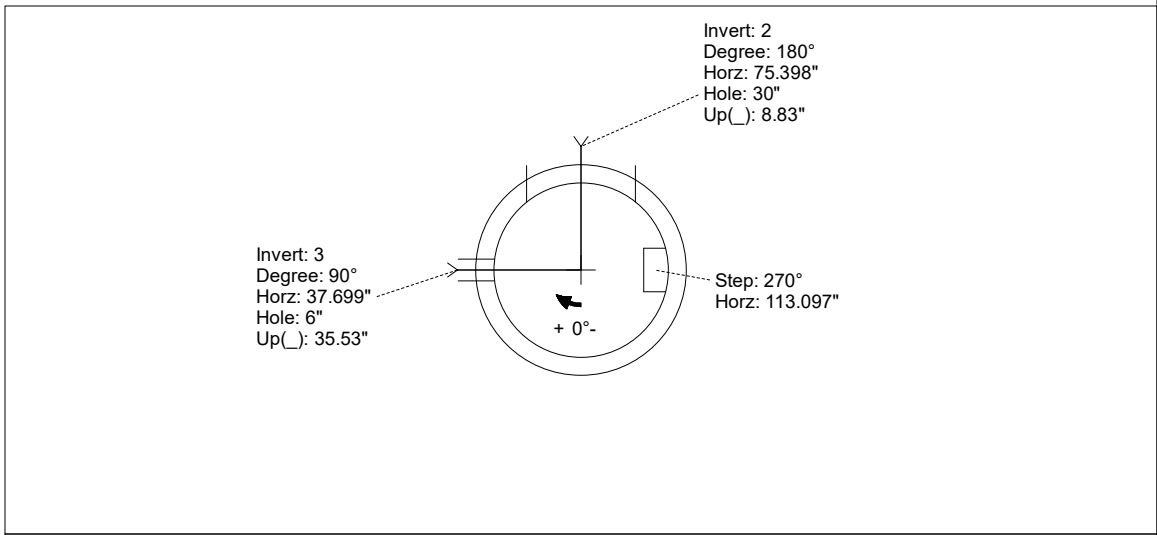
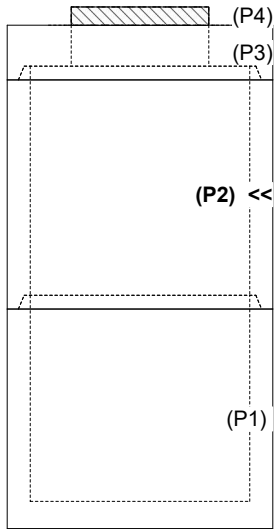

INSIDE WALL DIMENSIONS

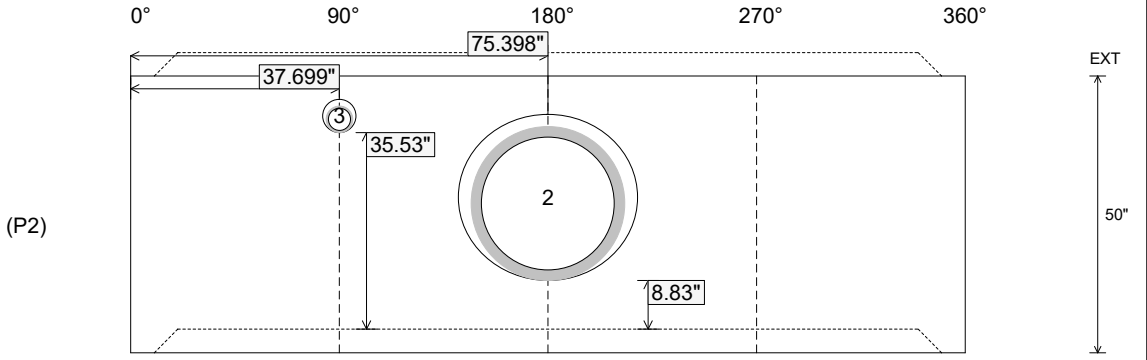

Coating (Int):	Seam Up: Tongue	Wall Thickness: 5"	Height (Int): 50"	Weight (Net): 3165 lb
Coating (Ext):	Seam Dn: Groove	Floor Height: 0"	Height (Ext): 50"	Volume (Net): 0.81cu.yd