

Job Name: 25-0209 Garrison Gardens
 Job Location: Bowling Green, KY
 Contractor: Scotty's Contracting & Stone, LLC

Plant: 100
 1/23/2026 4:35:47 PM

Tech: J. Horsley - A
 PC: Celina Goff



Structure ID: CB 3-3

P2 MH060RSVF

MH RISER Custom Ht F/G

- P4) 30" x 30" - CASTING HEIGHT - 4"
- P3) 60" - MH FLAT TOP w/30"x30" Hole F/F - 8"
- P2) 60" - MH RISER Custom Ht F/G - 43"
- P1) 60" - MH BASE T/n - 72"
- 1) CASTING - HOE 468 F/G
- 2) 60" - Conseal CS-102 1.00"
- 1) 30" x 30" - Conseal CS-102 1.00"
- 2) Hole - 38
- 1) Hole - 20
- 1) Hole - 6
- 6) MH Step ML-10-TDS-NCR - 10"

0 lb
 2239 lb
 4475 lb
 8869 lb
 489 lb
 0 lb
 0 lb
 0 lb
 0 lb
 0 lb
 0 lb

 16072 lb

- Structure Notes:**
1. PER ASTM C-478 SPECIFICATIONS
 2. CONCRETE: 4,000 PSI AT 28 DAYS
 3. REINFORCEMENT: PER ASTM A615
 4. STEPS AT 180 DEGREES
 5. HOE 468 FRAME & GRATE SUPPLIED BY ICAST

Structure Total: 16072 lb

Rim: 510.58' Rim to Invert: 10.41' Slack: 0.47" Sump: 2.55" Step Position: 180°

Position	Elev	Angle	Ext. (cw)	Pipe	Pipe OD	Connector	Hole	Horz Size	Up (↓)	Offset
Invert 1										
Invert 2										
Invert 3										
Invert 4	508.08'	315°	197.92"	4" HDPE (perf pipe)	4.8"	Hole 6	6"	6.01"	20.32"	0"
Invert 5										
Invert 6										
Invert 7										
Invert 8										

RIGHT-SIDE UP VIEW (int. dimensions)

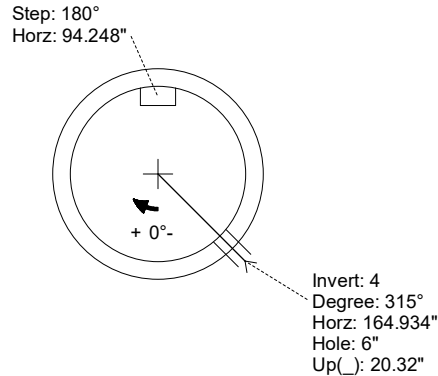
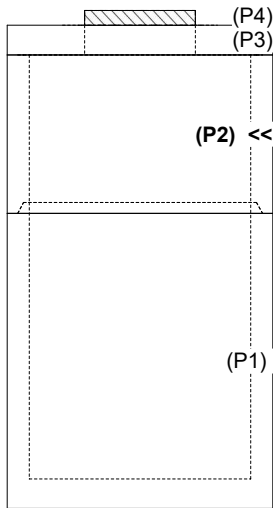

INSIDE WALL DIMENSIONS

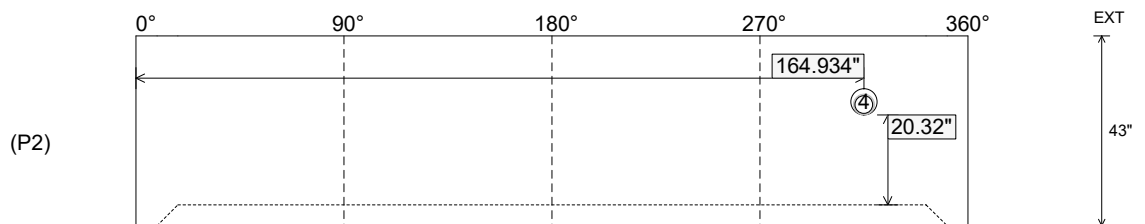

Coating (Int):
 Coating (Ext):

Seam Up: Flat
 Seam Dn: Groove

Wall Thickness: 6"
 Floor Height: 0"

Height (Int): 43"
 Height (Ext): 43"

Weight (Net): 4475 lb
 Volume (Net): 1.14cu.yd