

Job Name: 25-0209 Garrison Gardens  
 Job Location: Bowling Green, KY  
 Contractor: Scotty's Contracting & Stone, LLC

Plant: 100  
 1/23/2026 4:35:46 PM

Tech: J. Horsley - A  
 PC: Celina Goff



**Structure ID: CB 3-2**

**P3 MH048RS48S**

**MH RISER SPECIAL T/G**

P5) 30" x 30" - CASTING HEIGHT - 4"	0 lb
P4) 48" - MH FLAT TOP w/30"x30" Hole F/G - 12"	1350 lb
P3) 48" - MH RISER SPECIAL T/G - 48"	3341 lb
P2) 60" - MH Transition Slab 48" Hole T/G - 13"	1928 lb
P1) 60" - MH BASE Custom Ht T/n - 68"	8612 lb
1) CASTING - HOE 468 F/G	489 lb
1) 60" - Conseal CS-102 1.00"	0 lb
2) 48" - Conseal CS-102 1.00"	0 lb
1) 30" x 30" - Conseal CS-102 1.00"	0 lb
2) Hole - 38	0 lb
1) Hole - 6	0 lb
9) MH Step ML-10-TDS-NCR - 10"	0 lb
Structure Total:	15720 lb

**Structure Notes:**  
 1. PER ASTM C-478 SPECIFICATIONS  
 2. CONCRETE: 4,000 PSI AT 28 DAYS  
 3. REINFORCEMENT: PER ASTM A615  
 4. STEPS AT 270 DEGREES  
 5. HOE 468 FRAME & GRATE SUPPLIED BY ICAST

Rim: 509.51' Rim to Invert: 11.87' Slack: -0.01" Sump: 2.55" Step Position: 270°

Position	Elev	Angle	Ext. (cw)	Pipe	Pipe OD	Connector	Hole	Horz Size	Up (L)	Offset
Invert 1										
Invert 2										
Invert 3	507.01'	225°	113.883"	4" HDPE (perf pipe)	4.8"	Hole 6	6"	6.016"	29.34"	0"
Invert 4										
Invert 5										
Invert 6										
Invert 7										
Invert 8										

**RIGHT-SIDE UP VIEW (int. dimensions)**

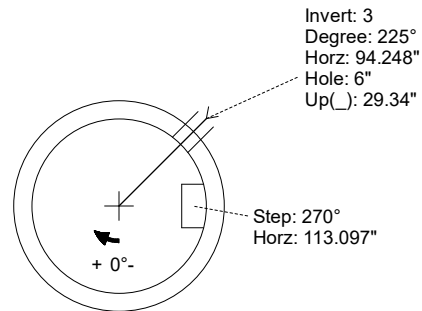
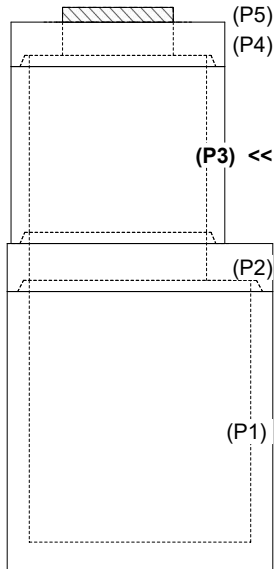

**INSIDE WALL DIMENSIONS**

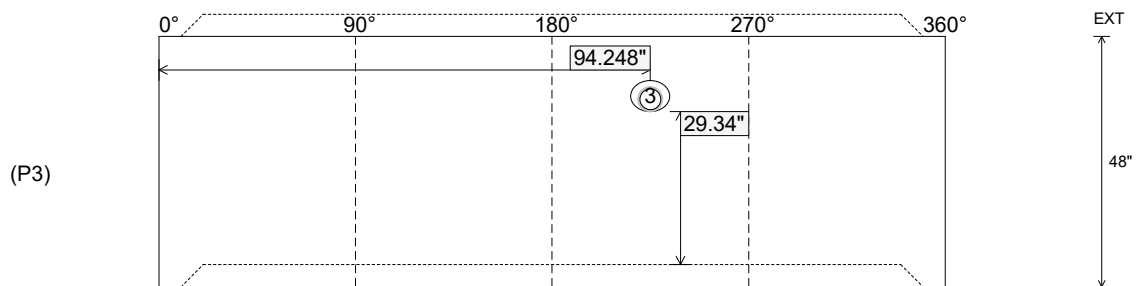

Coating (Int):  
 Coating (Ext):

Seam Up: Tongue  
 Seam Dn: Groove

Wall Thickness: 5"  
 Floor Height: 0"

Height (Int): 48"  
 Height (Ext): 48"

Weight (Net): 3341 lb  
 Volume (Net): 0.85cu.yd