

Job Name: 25-0209 Garrison Gardens
 Job Location: Bowling Green, KY
 Contractor: Scotty's Contracting & Stone, LLC

Plant: 100

Tech: J. Horsley - A

1/23/2026 4:35:50 PM

PC: Celina Goff



Structure ID: CB 2-2

P2 MH048RSVF

MH RISER Custom Ht T/G

- P4) 30" x 30" - CASTING HEIGHT - 4"
- P3) 48" - MH FLAT TOP w/30"x30" Hole F/G - 12"
- P2) 48" - MH RISER Custom Ht T/G - 59"
- P1) 48" - MH BASE T/n - 36"
- 1) CASTING - HOE 468 F/G
- 2) 48" - Conseal CS-102 1.00"
- 1) 30" x 30" - Conseal CS-102 1.00"
- 2) Hole - 30
- 1) Hole - 6
- 8) MH Step ML-10-TDS-NCR - 10"

0 lb
 1350 lb
 3794 lb
 3529 lb
 489 lb
 0 lb
 0 lb
 0 lb
 0 lb
 0 lb

 Structure Total: 9162 lb

- Structure Notes:**
1. PER ASTM C-478 SPECIFICATIONS
 2. CONCRETE: 4,000 PSI AT 28 DAYS
 3. REINFORCEMENT: PER ASTM A615
 4. STEPS AT 180 DEGREES
 5. HOE 468 FRAME & GRATE SUPPLIED BY ICAST

Rim: 506.86' Rim to Invert: 9.13' Slack: 0.46" Sump: 1.9" Step Position: 180°

Position	Elev	Angle	Ext. (cw)	Pipe	Pipe OD	Connector	Hole	Horz Size	Up (⌋)	Offset
Invert 1										
Invert 2	501.77'	257°	130.079"	24" HDPE	27.8"	Hole 30	30"	32.406"	8.23"	0"
Invert 3	504.61'	150°	75.922"	4" HDPE (perf pipe)	4.8"	Hole 6	6"	6.016"	43.81"	0"
Invert 4										
Invert 5										
Invert 6										
Invert 7										
Invert 8										

RIGHT-SIDE UP VIEW (int. dimensions)

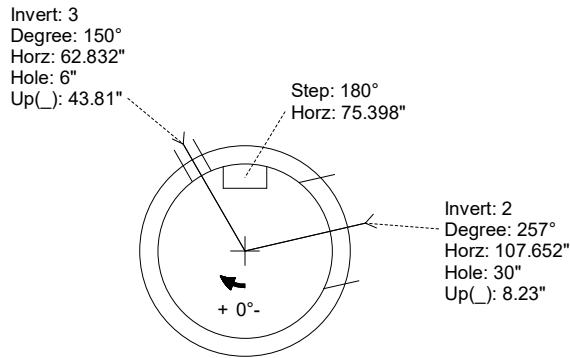
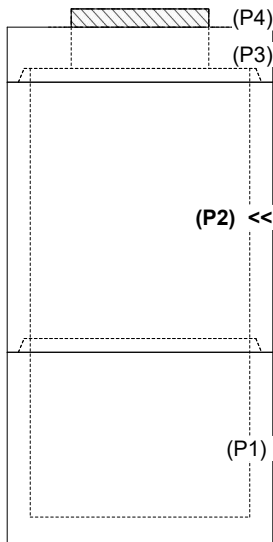

INSIDE WALL DIMENSIONS

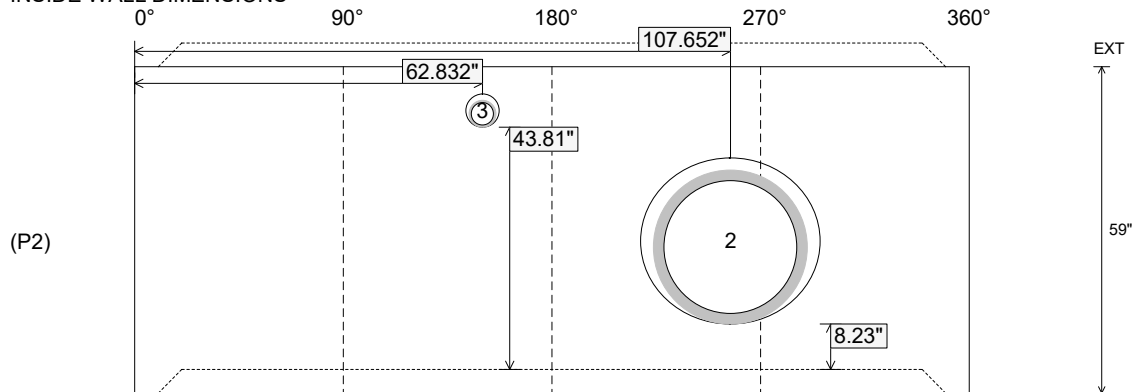

Coating (Int):
 Coating (Ext):

Seam Up: Tongue
 Seam Dn: Groove

Wall Thickness: 5"
 Floor Height: 0"

Height (Int): 59"
 Height (Ext): 59"

Weight (Net): 3794 lb
 Volume (Net): 0.97cu.yd