

Job Name: 25-0209 Garrison Gardens  
 Job Location: Bowling Green, KY  
 Contractor: Scotty's Contracting & Stone, LLC

Plant: 100  
 1/23/2026 4:31:58 PM

Tech: J. Horsley - A  
 PC: Celina Goff



**Structure ID: CB 1-5**

**P1 MH060BAVF**

**MH BASE Custom Ht T/n**

- P3) 30" x 30" - CASTING HEIGHT - 4"
- P2) 60" - MH FLAT TOP w/30"x30" Hole F/G - 13"
- P1) 60" - MH BASE Custom Ht T/n - 69"
- 1) CASTING - HOE 468 F/G
- 1) 60" - Conseal CS-102 1.00"
- 1) 30" x 30" - Conseal CS-102 1.00"
- 2) Hole - 38
- 6) MH Step ML-10-TDS-NCR - 10"

0 lb  
 2400 lb  
 8716 lb  
 489 lb  
 0 lb  
 0 lb  
 0 lb  
 0 lb  
 -----  
 11605 lb

Structure Total:

- Structure Notes:**
1. PER ASTM C-478 SPECIFICATIONS
  2. CONCRETE: 4,000 PSI AT 28 DAYS
  3. REINFORCEMENT: PER ASTM A615
  4. NO STORM INVERT
  5. STEPS AT 270 DEGREES
  6. HOE 468 FRAME & GRATE SUPPLIED BY ICAST

Rim: 515.5' Rim to Invert: 7.02' Slack: 0.79" Sump: 2.55" Step Position: 270°

Position	Elev	Angle	Ext. (cw)	Pipe	Pipe OD	Connector	Hole	Horz Size	Up ( )	Offset
Invert 1	508.48'	0°	0"	30" HDPE	35.1"	Hole 38	38"	41.151"	0"	0"
Invert 2	508.48'	180°	113.097"	30" HDPE	35.1"	Hole 38	38"	41.151"	0"	0"
Invert 3										
Invert 4										
Invert 5										
Invert 6										
Invert 7										
Invert 8										

RIGHT-SIDE UP VIEW (int. dimensions)

UPSIDE-DOWN VIEW (int. dimensions)

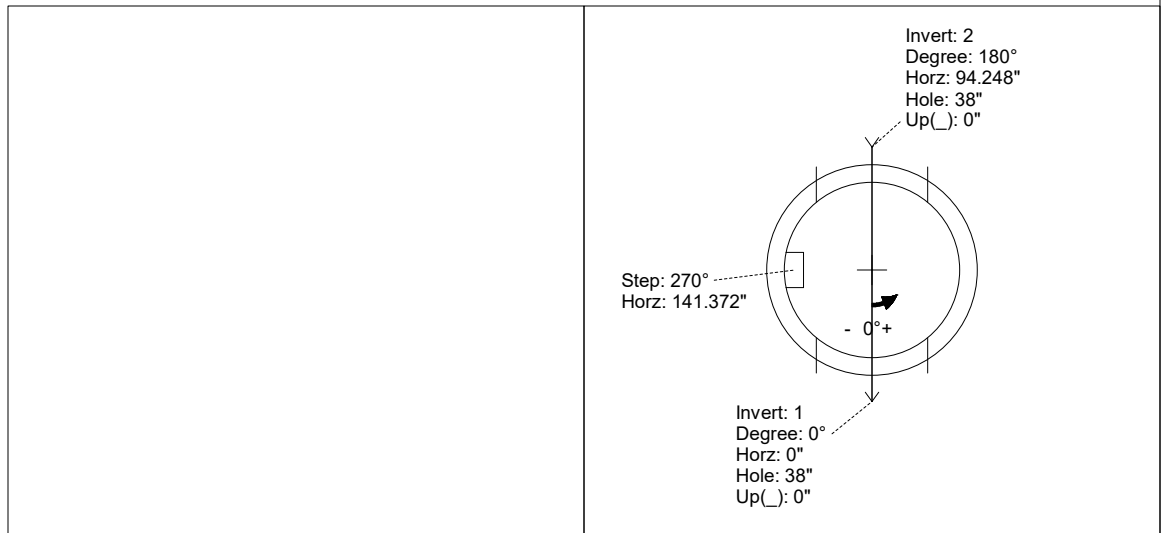
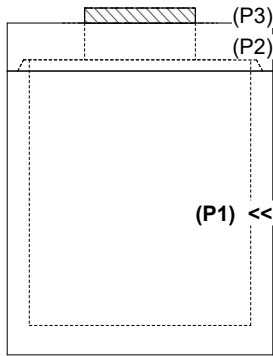

INSIDE WALL DIMENSIONS

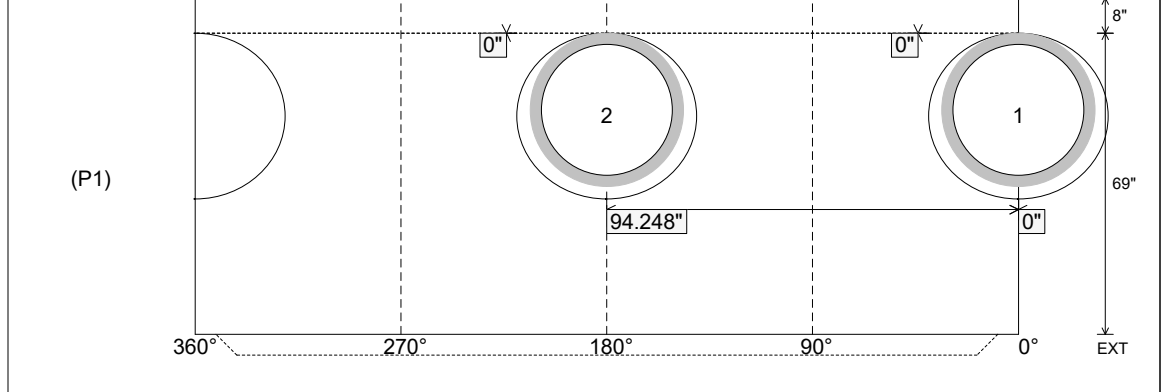

Coating (Int):  
 Coating (Ext):

Seam Up: Tongue  
 Seam Dn: n/a

Wall Thickness: 6"  
 Floor Height: 8"

Height (Int): 69"  
 Height (Ext): 77"

Weight (Net): 8716 lb  
 Volume (Net): 2.23cu.yd