

Job Name: 25-0209 Garrison Gardens
 Job Location: Bowling Green, KY
 Contractor: Scotty's Contracting & Stone, LLC

Plant: 100
 1/23/2026 4:36:11 PM

Tech: J. Horsley - A
 PC: Celina Goff



Structure ID: CB 1-4

P2 MH060LD08-30SQ

MH FLAT TOP w/30"x30" Hole F/F

- P3) 30" x 30" - CASTING HEIGHT - 4"
- P2) 60" - MH FLAT TOP w/30"x30" Hole F/F - 8"
- P1) 60" - MH BASE F/n - 60"
- 1) CASTING - HOE 468 F/G
- 1) 60" - Conseal CS-102 1.00"
- 1) 30" x 30" - Conseal CS-102 1.00"
- 2) Hole - 38
- 5) MH Step ML-10-TDS-NCR - 10"

0 lb
 2239 lb
 7777 lb
 489 lb
 0 lb
 0 lb
 0 lb
 0 lb

 10505 lb

Structure Total:

- Structure Notes:**
1. PER ASTM C-478 SPECIFICATIONS
 2. CONCRETE: 4,000 PSI AT 28 DAYS
 3. REINFORCEMENT: #5 BAR @ 6" C.C. E.W. (GRADE 60) - 2" MIN. REBAR CLEARANCE (TYP)
 4. HOE 468 FRAME & GRATE SUPPLIED BY ICAST
 5. LIFTERS: 4 EA. WRA016 CONAC WIRE ROPE ANCHORS FOR PLANT & FIELD HANDLING
 6. TOP SURFACE TO RECEIVE FLOATED FINISH

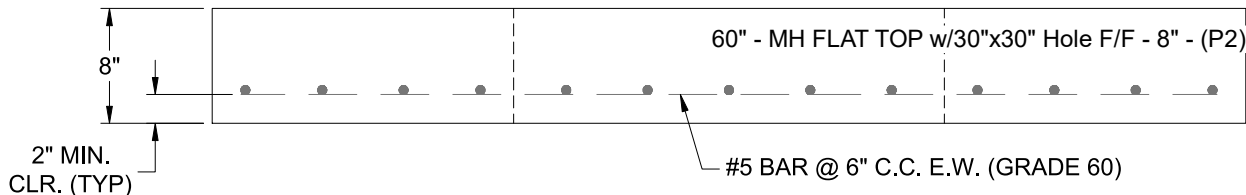
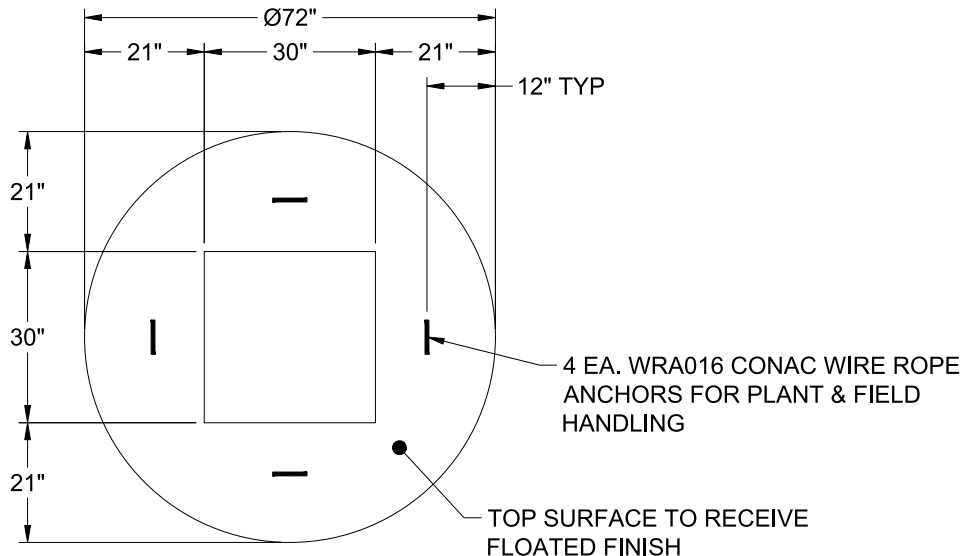

Coating (Int):
 Coating (Ext):

Seam Up: Flat
 Seam Dn: Flat

Wall Thickness: 6"

Height (Ext): 8"

Weight (Net): 2239 lb
 Volume (Net): 0.57cu.yd