

Job Name: 25-0209 Garrison Gardens	Plant: 100	Tech: J. Horsley - A	
Job Location: Bowling Green, KY	1/23/2026 4:35:46 PM	PC: Celina Goff	
Contractor: Scotty's Contracting & Stone, LLC			

Structure ID: CB 1-3

P2 MH060RSVF

MH RISER Custom Ht T/G

P4) 30" x 30" - CASTING HEIGHT - 4"	0 lb
P3) 60" - MH FLAT TOP w/30"x30" Hole F/G - 13"	2400 lb
P2) 60" - MH RISER Custom Ht T/G - 64"	6057 lb
P1) 60" - MH BASE Custom Ht T/n - 44"	6717 lb
1) CASTING - HOE 468 F/G	489 lb
2) 60" - Conseal CS-102 1.00"	0 lb
1) 30" x 30" - Conseal CS-102 1.00"	0 lb
2) Hole - 38	0 lb
1) Hole - 6	0 lb
3) MH Step ML-10-TDS-NCR - 10"	0 lb
Structure Total:	15662 lb

Structure Notes:

- PER ASTM C-478 SPECIFICATIONS
- CONCRETE: 4,000 PSI AT 28 DAYS
- REINFORCEMENT: PER ASTM A615
- STEPS AT 270 DEGREES
- HOE 468 FRAME & GRATE SUPPLIED BY ICAST

Rim: 509.32' Rim to Invert: 10.24' Slack: 0.43" Sump: 2.55" Step Position: 270°

Position	Elev	Angle	Ext. (cw)	Pipe	Pipe OD	Connector	Hole	Horz Size	Up ()	Offset
Invert 1										
Invert 2	503.72'	188°	118.124"	30" HDPE	35.1"	Hole 38	38"	41.151"	6.93"	0"
Invert 3	506.82'	90°	56.549"	4" HDPE (perf pipe)	4.8"	Hole 6	6"	6.01"	46.28"	0"
Invert 4										
Invert 5										
Invert 6										
Invert 7										
Invert 8										

RIGHT-SIDE UP VIEW (int. dimensions)

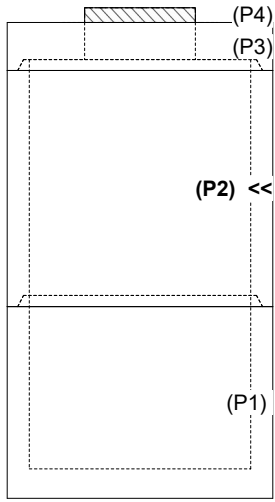
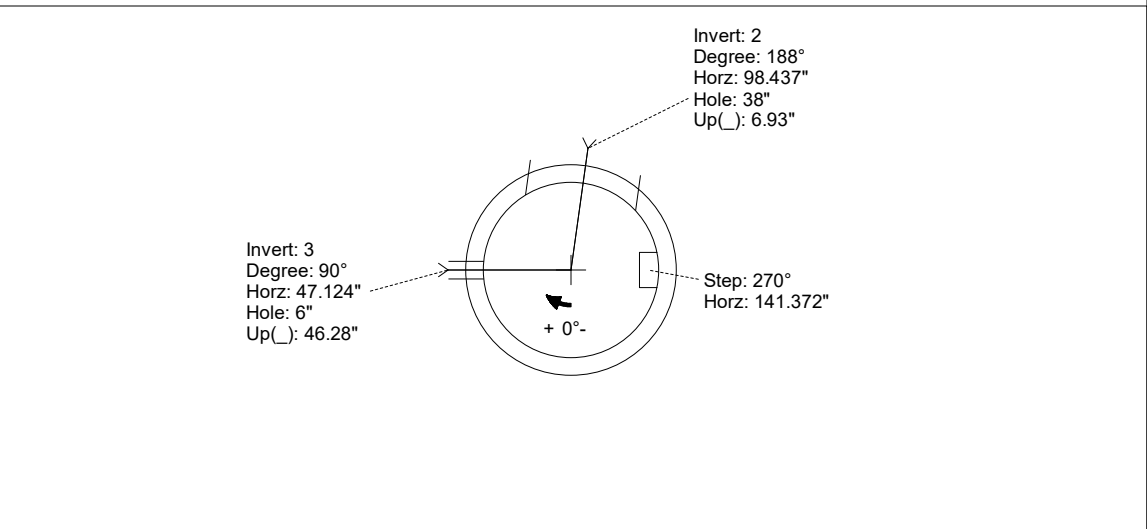

INSIDE WALL DIMENSIONS

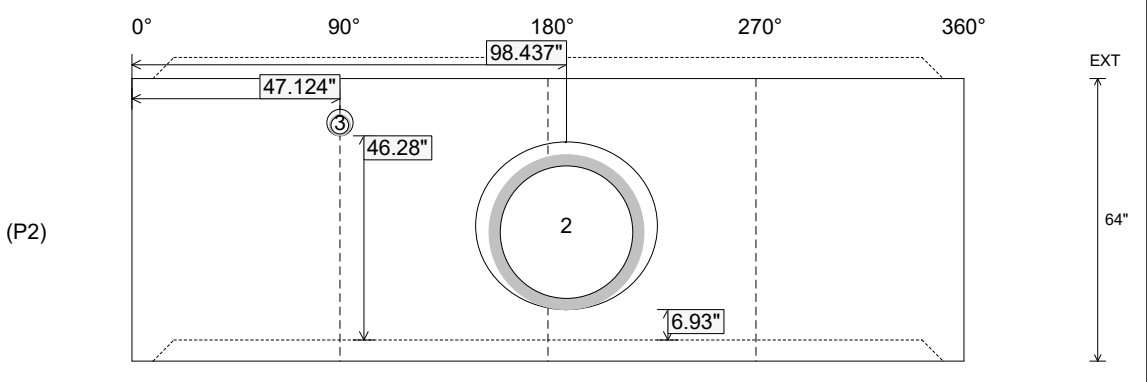

Coating (Int): Coating (Ext):	Seam Up: Tongue Seam Dn: Groove	Wall Thickness: 6" Floor Height: 0"	Height (Int): 64" Height (Ext): 64"	Weight (Net): 6057 lb Volume (Net): 1.55cu.yd
----------------------------------	------------------------------------	----------------------------------------	----------------------------------------	--------------------------------------------------