

Job Name: 25-0209 Garrison Gardens
 Job Location: Bowling Green, KY
 Contractor: Scotty's Contracting & Stone, LLC

Plant: 100
 1/23/2026 4:31:57 PM

Tech: J. Horsley - A
 PC: Celina Goff



Structure ID: CB 1-3

P1 MH060BAVF

MH BASE Custom Ht T/n

- P4) 30" x 30" - CASTING HEIGHT - 4"
- P3) 60" - MH FLAT TOP w/30"x30" Hole F/G - 13"
- P2) 60" - MH RISER Custom Ht T/G - 64"
- P1) 60" - MH BASE Custom Ht T/n - 44"
- 1) CASTING - HOE 468 F/G
- 2) 60" - Conseal CS-102 1.00"
- 1) 30" x 30" - Conseal CS-102 1.00"
- 2) Hole - 38
- 1) Hole - 6
- 3) MH Step ML-10-TDS-NCR - 10"

0 lb
 2400 lb
 6057 lb
 6717 lb
 489 lb
 0 lb
 0 lb
 0 lb
 0 lb
 0 lb
 0 lb
 Structure Total: 15662 lb

- Structure Notes:**
1. PER ASTM C-478 SPECIFICATIONS
 2. CONCRETE: 4,000 PSI AT 28 DAYS
 3. REINFORCEMENT: PER ASTM A615
 4. NO STORM INVERT
 5. STEPS AT 270 DEGREES
 6. HOE 468 FRAME & GRATE SUPPLIED BY ICAST

Rim: 509.32' Rim to Invert: 10.24' Slack: 0.43" Sump: 2.55" Step Position: 270°

| Position | Elev | Angle | Ext. (cw) | Pipe | Pipe OD | Connector | Hole | Horz Size | Up () | Offset |
|----------|---------|-------|-----------|----------|---------|-----------|------|-----------|--------|--------|
| Invert 1 | 499.08' | 0° | 0" | 30" HDPE | 35.1" | Hole 38 | 38" | 41.151" | 0" | 0" |
| Invert 2 | | | | | | | | | | |
| Invert 3 | | | | | | | | | | |
| Invert 4 | | | | | | | | | | |
| Invert 5 | | | | | | | | | | |
| Invert 6 | | | | | | | | | | |
| Invert 7 | | | | | | | | | | |
| Invert 8 | | | | | | | | | | |

RIGHT-SIDE UP VIEW (int. dimensions)

UPSIDE-DOWN VIEW (int. dimenions)

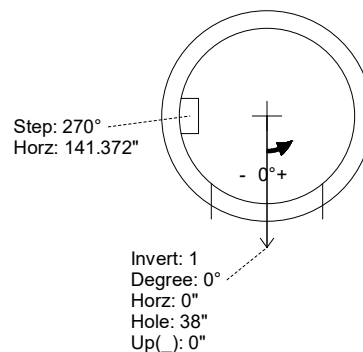
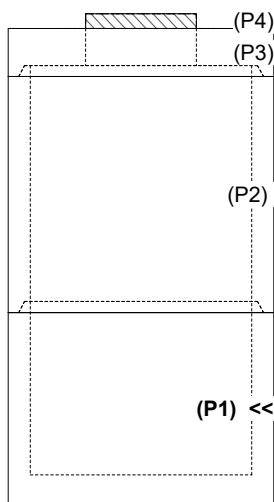

INSIDE WALL DIMENSIONS

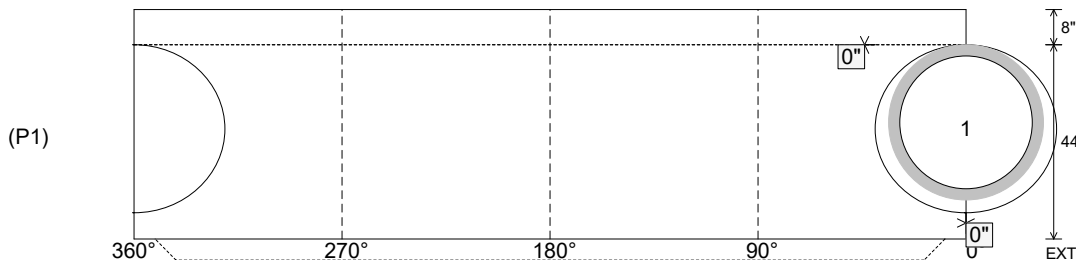

Coating (Int):
 Coating (Ext):

Seam Up: Tongue
 Seam Dn: n/a

Wall Thickness: 6"
 Floor Height: 8"

Height (Int): 44"
 Height (Ext): 52"

Weight (Net): 6717 lb
 Volume (Net): 1.72cu.yd