

Job Name: 25-0199 - Countryview Stormwater Imp. Ph. 3 Sec. 1
 Job Location: Henderson, KY 42420
 Contractor: Koberstein Contracting, Inc.

Plant: Beaver Dam, KY
 10/20/2025 12:26:39 PM

Tech: K. Cardwell
 PC: E. Bradley



Structure ID: 106

P1 MH060BA54

MH BASE T/n

- P5) 24" - CASTING HEIGHT - 7"
- P4) 24" - GRADE RING F/F - 3"
- P3) 60" - MH FLAT TOP w/24" Ctr. Hole F/G - 13"
- P2) 60" - MH RISER SPECIAL T/G - 36"
- P1) 60" - MH BASE T/n - 54"
- 2) 60" - Conseal CS-102 1.00"
- 2) Hole - 38
- 2) Hole - 16

0 lb
 202 lb
 2674 lb
 3554 lb
 7151 lb
 0 lb
 0 lb
 0 lb

 Structure Total: 13580 lb

Structure Notes:
 STATION: 3+84 LN A
 1. PER ASTM C-478 SPECS
 2. CONCRETE: 4,000 PSI AT 28 DAYS
 3. REINFORCEMENT: PER ASTM A615
 4. NO STEPS
 5. 7" CASTING SUPPLIED BY OTHERS

Rim: 377.81' Rim to Invert: 9.39' Slack: 2.23' Sump: 2.55" Step Position:

Position	Elev	Angle	Ext. (cw)	Pipe	Pipe OD	Connector	Hole	Horz Size	Up ()	Offset
Invert 1	368.42'	0°	0"	30" ADS N-12	35.1"	Hole 38	38"	41.151"	0"	0"
Invert 2										
Invert 3	368.42'	227°	142.628"	30" ADS N-12	35.1"	Hole 38	38"	41.151"	0"	0"
Invert 4										
Invert 5										
Invert 6										
Invert 7										
Invert 8										

RIGHT-SIDE UP VIEW (int. dimensions)

UPSIDE-DOWN VIEW (int. dimenions)

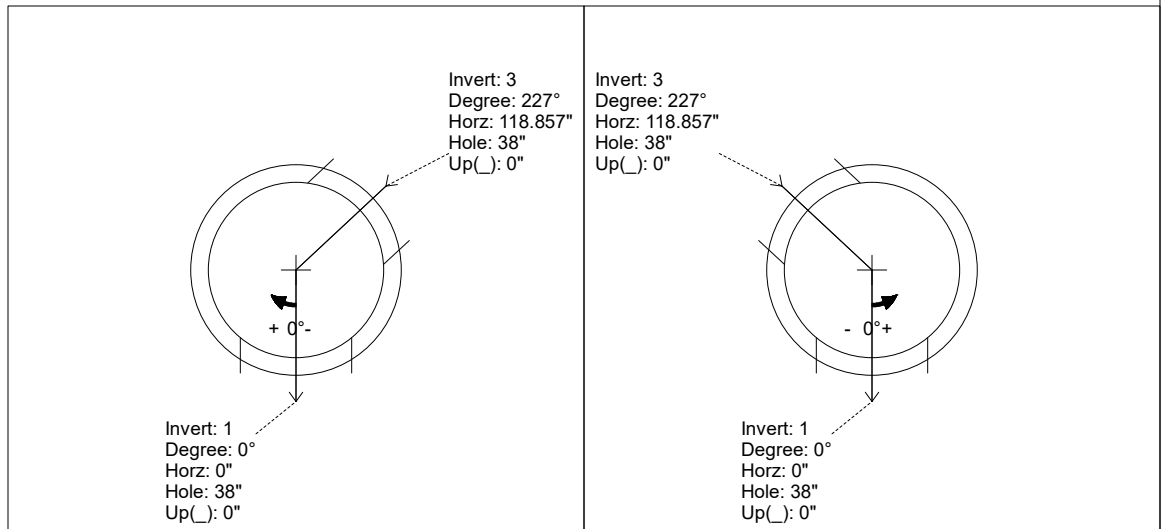
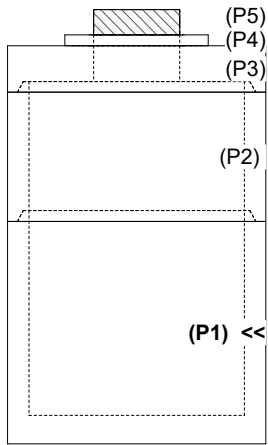

INSIDE WALL DIMENSIONS

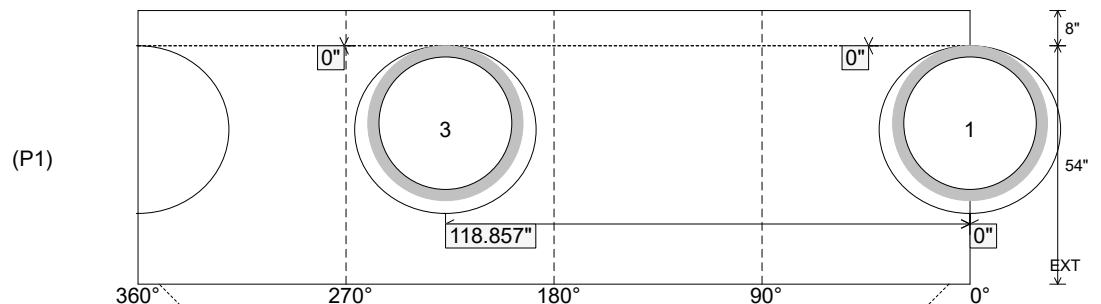

Coating (Int):
 Coating (Ext):

Seam Up: Tongue
 Seam Dn: n/a

Wall Thickness: 6"
 Floor Height: 8"

Height (Int): 54"
 Height (Ext): 62"

Weight (Net): 7151 lb
 Volume (Net): 1.83cu.yd