

Job Name: 24-4317 Sumner Co Regional Transmission Line C
 Job Location: Gallatin, TN
 Contractor: Endesol, Inc.

Plant: Beaver Dam

Tech: J. Coppage

12/9/2025 10:40:37 AM

PC: J. Jarvis



Structure ID: 10IN FLOW CONTROL VAULT

P2 BX7296-06W06T-VF-MT

BX MONOTOP 6"W/6"T w/48"x48" HATCH

- P3) 48" x 48" - HATCH (CAST FLUSH) - 3"
- P2) 72" x 96" - BX MONOTOP 6"W/6"T w/48"x48" HATCH - 27.5"
- P1) 72" x 96" - BOX BASE 6inW, 6inF, Variable Ht - 44.5"
- 1) This Structure Includes a Cast-in Item
- 1) SUMP DISH
- 1) 72" x 96" - Conseal CS-102 1.00"
- 1) 48" x 48" - Conseal CS-102 1.00"
- 2) Hole - 12
- 4) MH Step ML-10-TDS-NCR - 10"

- Structure Notes:
1. HALLIDAY W1S 48" X 48" HATCH BY ICAST.
 2. PER ASTM C913 SPECIFICATIONS.
 3. CONCRETE = 4,000 PSI AT 28 DAYS.
 4. REINFORCING PER ASTM A615 (GRADE 60).
 - TOP SLAB (As .62) #5 BARS AT 6" C.C.E.W.
 - WALLS (As .31) #5 BARS AT 8" C.C.E.W.
 - FLOOR (As .31) #5 BARS AT 8" C.C.E.W..

Structure Total: 21011 lb

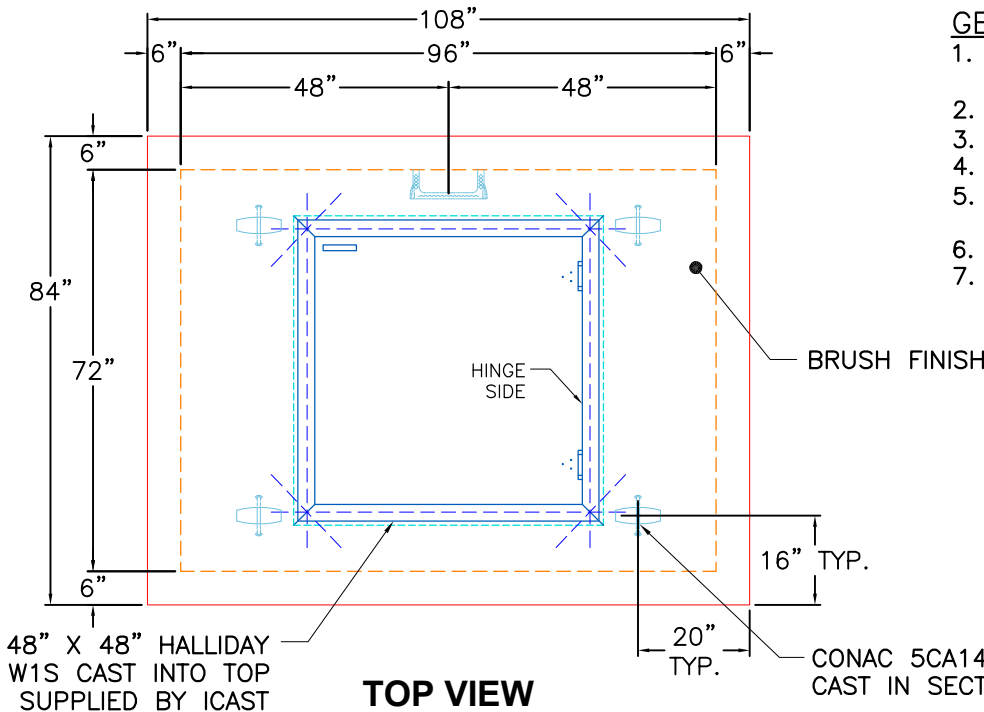

GENERAL NOTES:

1. MANUFACTURED TO ASTM C-913 (LATEST REVISION).
2. CONCRETE: 5,000 PSI AT 28 DAYS.
3. REINFORCING: #5 BAR @ 8" O.C.E.W
4. WEIGHT = 8,392 LBS
5. HALLIDAY W1S 48" X 48" HATCH PROVIDED BY ICAST.
6. HATCH TO BE CAST INTO TOP SECTION.
7. SLOPE TO FLOOR BY OTHERS.

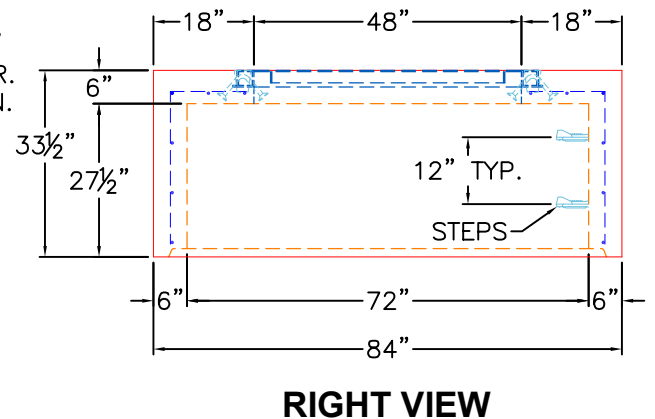
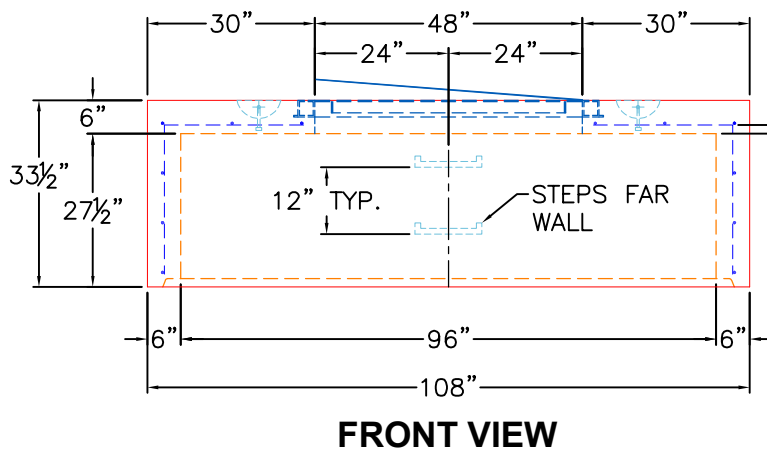

Coating (Int):
 Coating (Ext):

Seam Up: Flat
 Seam Dn: Groove

Wall Thickness: 6"

Height (Ext): 33.5"

Weight (Net): 8392 lb
 Volume (Net): 2.14cu.yd